

# 3 Port Air Operated Valve Series VTA301

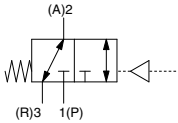

Symbol



## How to Order

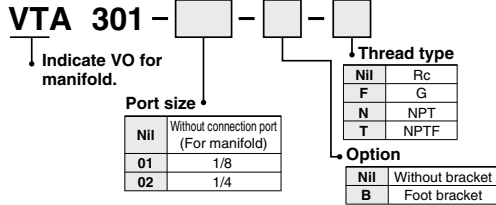

## Specifications

Fluid	Air
Operating pressure range (MPa)	0 to 1.0
Pilot pressure range (MPa)	0.2 to 1.0
Ambient and fluid temperature (°C)	-10 to 50 (No freezing. Refer to page 5.)
Lubrication	Not required (Use turbine oil Class 1 ISO VG32, if lubricated.)
Impact/Vibration resistance (m/s <sup>2</sup> ) <sup>Note)</sup>	150/50
Enclosure	Dustproof

Note) Impact resistance: No malfunction from test using drop impact tester, to axis and right angle directions of main valve, each one time when pilot signal ON and OFF. (Value in the initial stage)

Vibration resistance: No malfunction from test with 45 to 2000 Hz one sweep, to axis and right angle direction of main valve, each one time when pilot signal ON and OFF. (Value in the initial stage)

## Option

Description	Part no.
Bracket (With screw)	DXT060-27A

## Flow Characteristics/Weight

Valve model	Port size	Flow characteristics												Weight (kg)
		1→2(P→A)			2→3(A→R)			3→2(R→A)			2→1(A→P)			
		C <sub>d</sub> [dm <sup>3</sup> /(s·bar)]	b	C <sub>v</sub>	C <sub>d</sub> [dm <sup>3</sup> /(s·bar)]	b	C <sub>v</sub>	C <sub>d</sub> [dm <sup>3</sup> /(s·bar)]	b	C <sub>v</sub>	C <sub>d</sub> [dm <sup>3</sup> /(s·bar)]	b	C <sub>v</sub>	
VTA301-01-□-□	1/8	0.63	0.30	0.16	0.59	0.30	0.15	0.59	0.32	0.15	0.65	0.30	0.16	0.11
VTA301-02-□-□	1/4	0.66	0.28	0.16	0.60	0.29	0.15	0.61	0.32	0.15	0.66	0.30	0.16	With bracket: 0.13
VOA301	Without connection port	0.34	0.26	0.084	0.32	0.17	0.076	0.35	0.22	0.084	0.35	0.13	0.079	0.12

Note 1) The pilot port size is 1/8.

Note 2) Flow characteristics of VOA301 is the value when the valve is mounted on a manifold.

## ⚠ Precautions

Be sure to read before handling. Refer to front matter 53 for Safety Instructions and pages 3 to 8 for 3/4/5 Port Solenoid Valve Precautions.

### For manifold

#### ⚠ Caution

1. Each valve is fixed on the manifold with two M4 mounting screws. Please tighten the screws properly when valves are reassembled.  
Screw tightening torque: 1.4 N·m
2. M4 or equivalent bolts should be tightened evenly to mount the valve onto the manifold base.
3. In the case of common exhaust type, pressurization or vacuum suction through R port is not possible.
4. In the case of 6 stations or more, supply pressure from both sides of P port.  
In the case of common exhaust type, exhaust air from both sides of R port as well.

## How to Order Manifold

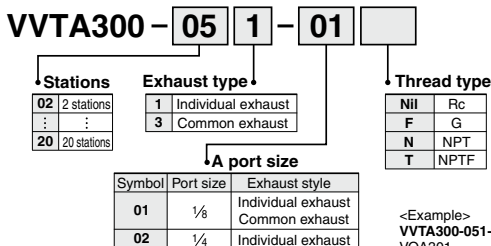

\* To order valves and blanking plate assembly mounted onto the manifold, list valves and blanking plate assembly with manifold base part number.

<Example>  
**VVTA300-051-01**..... 1 pc.  
 VOA301..... 4 pcs.  
 DXT060-51-13A..... 1 pc.

• Manifold bases same as those for Series VVT300 manifold valves are available. Please consult with SMC for the manifold specifications and precautions.

### Manifold Model

Model	Applicable manifold model	Accessory (Part no.)
VOA301	Common/Individual exhaust	Function plate (DXT060-32-4A)

### 6 Valve Functions Available by Changing of Piping Port

	3 port N.C.	3 port N.O.	2 port N.C.	2 port N.O.	Selector	Divider
Pilot OFF						
Pilot ON						

- SYA
- SYJA
- VZA
- VFA
- Vfra
- VPA4
- VSA4
- SYJA
- VZA
- VTA
- VGA
- VPA
- VPA3

# Series VTA301

## Dimensions/Base Mounted

VTA301-□□□

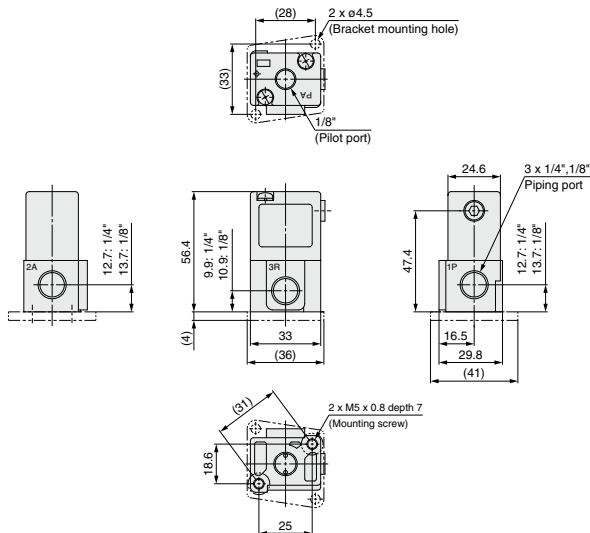

## Dimensions/Manifold

VVTA300-□□1

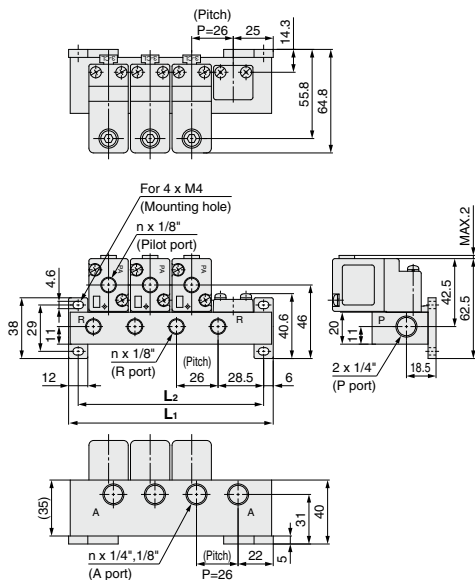

VVTA300-□□3

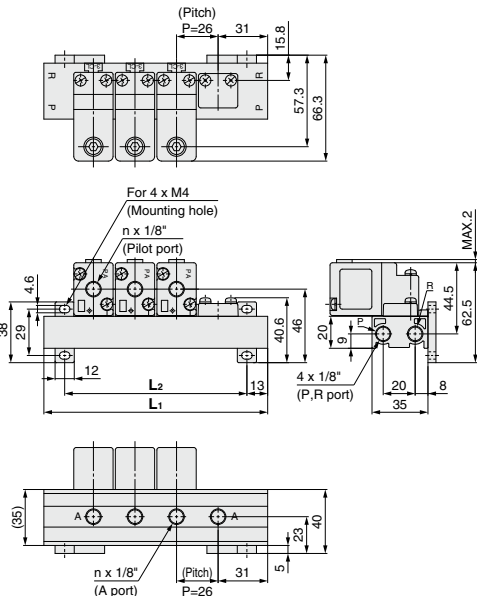

### Individual Exhaust

n: Station

Symbol	n	2	3	4	5	6	7	8	9	10
L <sub>1</sub>		76	102	128	154	180	206	232	258	284
L <sub>2</sub>		64	90	116	142	168	194	220	246	272

Calculation formula: L<sub>1</sub> = 26n + 24, L<sub>2</sub> = 26n + 12

2258

### Common Exhaust

n: Station

Symbol	n	2	3	4	5	6	7	8	9	10
L <sub>1</sub>		88	114	140	166	192	218	244	270	296
L <sub>2</sub>		62	88	114	140	166	192	218	244	270

Calculation formula: L<sub>1</sub> = 26n + 36, L<sub>2</sub> = 26n + 10

# 3 Port Air Operated Valve

# Series VTA315

## How to Order

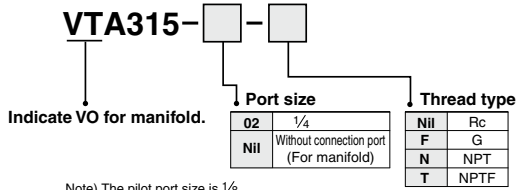

## How to Order Manifold

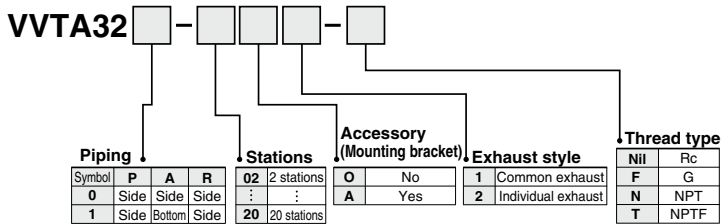

\* To order valves and blanking plate assembly mounted onto the manifold, list valves and blanking plate assembly with manifold base part number.

Example) VVTA320-0501..... 1 pc.  
VOA315..... 4 pcs.  
DXT010-36-2A..... 1 pc.

- Manifold bases same as those for Series VVT320 manifold valves are available. Refer to the separate catalog or "Series VT315" in SMC website (<http://www.smcworld.com>) for the manifold specifications and precautions.
- Port location on the bottom of a single valve for manifold is not related to the indication on the side of the body ① ② ③ (P, A, R). Refer to the Series VT315 on SMC website (<http://www.smcworld.com>).

## Manifold Model

Model	Applicable manifold model	Accessories
VOA315	Common/Individual exhaust	O-ring (KA00087: 4 pcs.), round head combination screw (DXT010-66-2: 2 pcs.)

SYA  
SYJA  
VZA  
VFA  
VFRA  
VPA4  
VSA4  
SYJA  
VZA  
VTA  
VGA  
VPA  
VPA3

# Series VTA315



Symbol

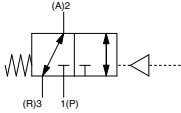

## Specifications

Fluid	Air
Operating pressure range (MPa)	0 to 1.0
Pilot pressure range (MPa)	0.1 to 1.0
Ambient and fluid temperature (°C)	-10 to 60 (No freezing. Refer to page 5.)
Lubrication	Not required (Use turbine oil Class 1 ISO VG32, if lubricated.)
Impact/Vibration resistance (m/s <sup>2</sup> ) <sup>Note</sup>	150/50
Enclosure	Dustproof

Note) Impact resistance: No malfunction from test using drop impact tester, to axis and right angle directions of main valve, each one time when pilot signal ON and OFF. (Value in the initial stage)

Vibration resistance: No malfunction occurs on the test with one sweep from 45 to 1000 Hz, to axis and right angle directions of main valve each time when pilot signal ON and OFF. (Value in the initial stage)

## Flow Characteristics/Weight

Valve model	Flow characteristics										Weight (kg)		
	1→2(P→A)			2→3(A→R)			3→2(R→A)			2→1(A→P)			
	C[dm <sup>3</sup> /(s-bar)]	b	Cv	C[dm <sup>3</sup> /(s-bar)]	b	Cv	C[dm <sup>3</sup> /(s-bar)]	b	Cv	C[dm <sup>3</sup> /(s-bar)]		b	Cv
VTA315	1.6	0.30	0.39	1.7	0.39	0.45	1.9	0.38	0.49	1.7	0.36	0.45	0.16
VOA315	1.4	0.12	0.33	1.2	0.18	0.29	1.5	0.16	0.35	1.2	0.13	0.28	



## Precautions

Be sure to read this before handling. Refer to front matter 53 for Safety Instructions and pages 3 to 8 for 3/4" Port Solenoid Valve Precautions.

## For manifold

### Caution

- Each valve is fixed on the manifold with two M4 mounting screws. Please tighten the screws properly when valves are reassembled.  
Screw tightening torque: 1.4 N·m
- When using 6 or more stations on the manifold, supply pressure from both sides of P port.  
In the case of common exhaust type, exhaust air from both sides of R port as well.

## Construction/Dimensions

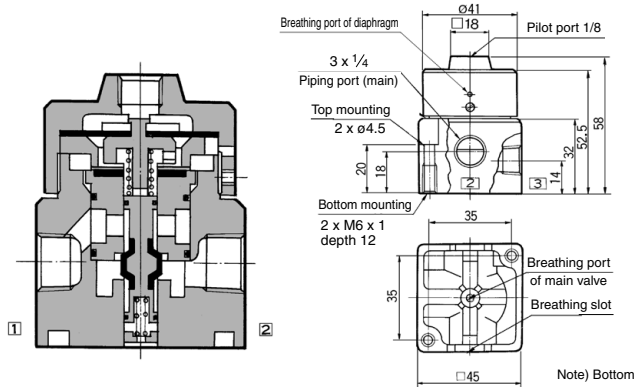

Note) Bottom

### Caution

- This valve has a breathing port for the main valve at the bottom. To prevent malfunctions, do not clog the breathing port. (When mounted on a metal surface, breathing air can go through from the breathing port to the breathing groove; however, when the valve is mounted on a rubber surface, the breathing air may be blocked by the deformation of rubber.)
- Take measures to prevent ingress of dust and foreign matter from the exhaust port and other unused ports. Also, take measures to prevent ingress of water and foreign matter from the breathing port of the diaphragm.