

172774-1 ✓ ACTIVE

AMP | Multilock Connector System

TE Internal #: 172774-1

Receptacle, Mating Tab Width 3 mm [.118 in], Tab Thickness .65 mm [.025 in], 20 – 14 AWG Wire Size, Multilock Connector System, Automotive Terminals

[View on TE.com >](#)



Terminals & Splices > Automotive Terminals > MULTILOCK, RECEPTACLE AND TAB



Terminal Type: **Receptacle**

Mating Tab Width: **3 mm [.118 in]**

Mating Tab Thickness: **.65 mm [.025 in]**

Terminal Transmits: **0 – 24 A (Low Power)**

Wire Size: **20 – 14 AWG**

[All MULTILOCK, RECEPTACLE AND TAB \(111\)](#)

## Features

### Product Type Features

Receptacle Style	180°
Sealable	No
Primary Locking Feature	Clean Body

### Contact Features

Contact Size	3mm
Contact Fabrication	Stamped & Formed
Wire Contact Termination Area Plating Material	Tin
Crimp Type	F-Crimp
Terminal Type	Receptacle
Mating Tab Width	3 mm [.118 in]
Mating Tab Thickness	.65 mm [.025 in]
Interface Plating	Tin (Sn)

### Termination Features

Termination Method to Wire & Cable	Crimp
Product Terminates To	Wire

### Dimensions



Compatible Insulation Diameter Range	2.1 – 3.38 mm [.082 – .133 in]
Wire Size	.5 – 2 mm <sup>2</sup>
Wire Size Search	14 AWG, 15 AWG, 16 AWG, 17 AWG, 18 AWG, 19 AWG, 20 AWG

### Usage Conditions

Insulation Option	Uninsulated
Operating Temperature (Max)	80 °C, 85 °C, 90 °C, 100 °C, 105 °C [176 °F] [185 °F][194 °F][212 °F][221 °F]
Operating Temperature Range	-30 – 105 °C [-22 – 221 °F]

### Packaging Features

Packaging Quantity	1000
Packaging Method	Bag

### Other

Terminal Transmits	0 – 24 A (Low Power)
--------------------	----------------------

## Product Compliance

[For compliance documentation, visit the product page on TE.com>](#)

EU RoHS Directive 2011/65/EU	Compliant
EU ELV Directive 2000/53/EC	Compliant
China RoHS 2 Directive MIIT Order No 32, 2016	No Restricted Materials Above Threshold
EU REACH Regulation (EC) No. 1907/2006	Current ECHA Candidate List: JUNE 2024 (241) Candidate List Declared Against: JUNE 2024 (241) Does not contain REACH SVHC
Halogen Content	Low Halogen - Br, Cl, F, I < 900 ppm per homogenous material. Also BFR/CFR/PVC Free
Solder Process Capability	Not applicable for solder process capability

#### Product Compliance Disclaimer

This information is provided based on reasonable inquiry of our suppliers and represents our current actual knowledge based on the information they provided. This information is subject to change. The part numbers that TE has identified as EU RoHS compliant have a maximum concentration of 0.1% by weight in homogenous materials for lead, hexavalent chromium, mercury, PBB, PBDE, DBP, BBP, DEHP, DIBP, and 0.01% for cadmium, or qualify for an exemption to these limits as defined in the Annexes of Directive 2011/65/EU (RoHS2). Finished electrical and electronic equipment products will be CE marked as required by Directive 2011/65/EU. Components may not be CE marked. Additionally, the part numbers that TE has identified as EU ELV compliant have a maximum concentration of 0.1% by weight in homogenous materials for lead, hexavalent chromium, and mercury, and 0.01% for cadmium, or qualify for an exemption to these limits as defined in the Annexes of Directive 2000/53/EC (ELV). Regarding the REACH Regulation, the information TE provides on SVHC in articles for this part number is based on the latest European Chemicals Agency (ECHA) 'Guidance on

requirements for substances in articles' posted at this URL: <https://echa.europa.eu/guidance-documents/guidance-on-reach>

## Compatible Parts



TE Part # 172500-1  
MIC MARK-2 PLUG HSG 17P



TE Part # 172494-1  
MIC MARK-2 PLUG HSG 5P



TE Part # 1804014-1  
CCII MIC MK-II REC 20-14 ASSY



TE Part # 753787-1  
EXTRACTION TOOL FOR MIC MK II

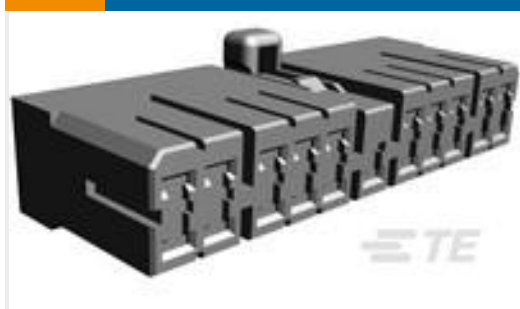

TE Part # 172501-1  
MIC MARK-2 PLUG HSG 21P



TE Part # 172496-1  
MIC PLUG HSG 9P (MK II)

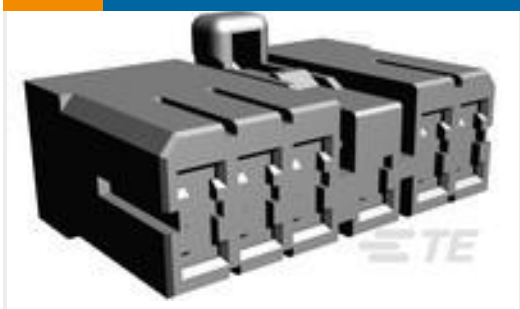

TE Part # 172497-1  
MIC MARK-2 PLUG HSG 11P

## Also in the Series | Multilock Connector System



Automotive Connector Caps & Covers  
(10)

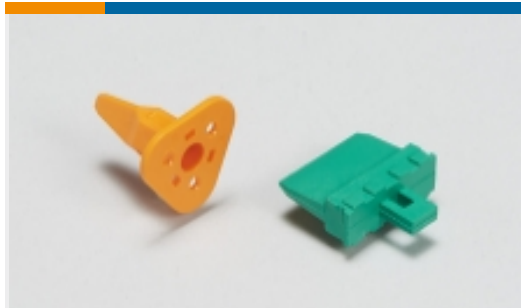

Automotive Connector Locks &  
Position Assurance(3)



Automotive Housings(445)

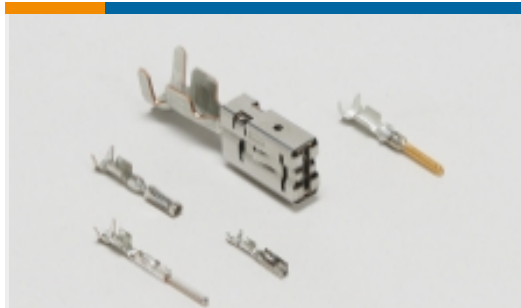

Automotive Terminals(118)



Connector Seals & Cavity Plugs(2)



Insertion & Extraction Tools(6)



Other Automotive Connector  
Accessories(12)

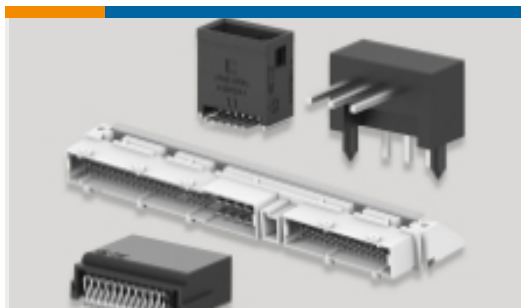

PCB Headers & Receptacles(134)

## Customers Also Bought

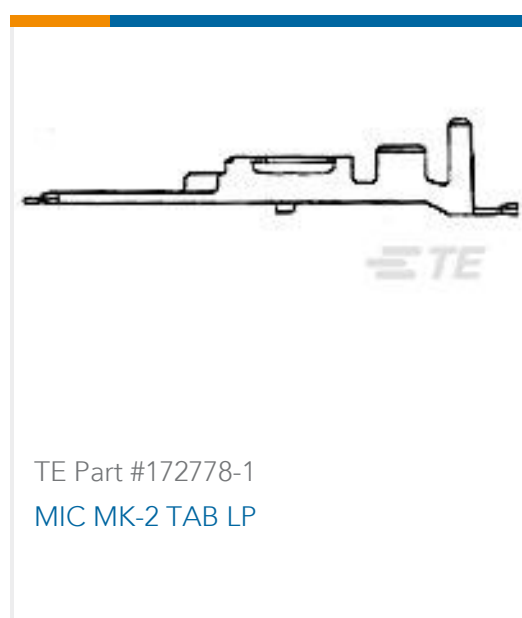

## Documents

### Product Drawings

RECP CONT MULTILOCK MIC MARKII

Japanese

### CAD Files

3D PDF

3D

Customer View Model

[ENG\\_CVM\\_CVM\\_172774-1\\_U.2d\\_dxf.zip](#)

English

Customer View Model

[ENG\\_CVM\\_CVM\\_172774-1\\_U.3d\\_igs.zip](#)

English

Customer View Model

[ENG\\_CVM\\_CVM\\_172774-1\\_U.3d\\_stp.zip](#)

English

By downloading the CAD file I accept and agree to the [Terms and Conditions](#) of use.

### Datasheets & Catalog Pages



## MULTILOCK Connector System

English

---

### Product Specifications

#### Application Specification

English

#### Crimping Multi-Interlock (MIC) Conn. Mark II, Rec. Contact

English

---

### Instruction Sheets

#### Instruction Sheet (non U.S.)

English

#### Multi-Interlock Mark II Contact From Plug & Cap HSG

English

#### Instruction Sheet (non U.S.)

Japanese