



GBU25005 THRU GBU2510

SINGLE PHASE 25.0 AMP BRIDGE RECTIFIERS



FEATURES

- * Ideal for printed circuit board
- * Low forward voltage
- * Low leakage current
- * Polarity: marked on body
- * Mounting position: Any

VOLTAGE RANGE

50 to 1000 Volts

CURRENT

25.0 Amperes

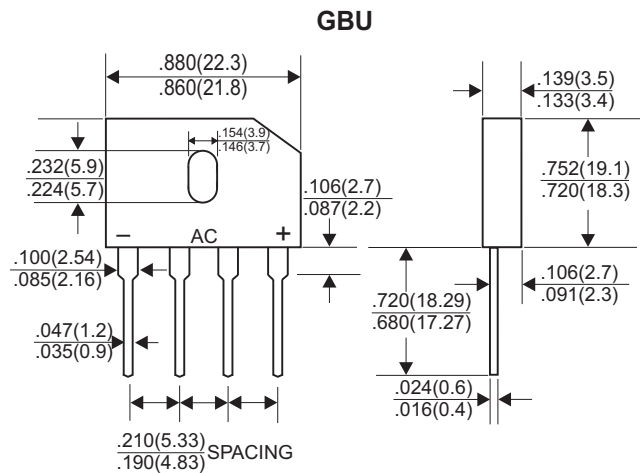

Dimensions in inches and (millimeters)

MAXIMUM RATINGS AND ELECTRICAL CHARACTERISTICS

Rating 25°C ambient temperature unless otherwise specified.
Single phase half wave, 60Hz, resistive or inductive load.
For capacitive load, derate current by 20%.

TYPE NUMBER	GBU25005	GBU2501	GBU2502	GBU2504	GBU2506	GBU2508	GBU2510	UNITS	
Maximum Recurrent Peak Reverse Voltage	50	100	200	400	600	800	1000	V	
Maximum RMS Voltage	35	70	140	280	420	560	700	V	
Maximum DC Blocking Voltage	50	100	200	400	600	800	1000	V	
Maximum Average Forward (with heatsink Note 2)								25.0	A
.375"(9.5mm) Lead Length at Tc=100°C (Without heatsink)								4.2	A
Peak Forward Surge Current, 8.3 ms single half sine-wave superimposed on rated load (JEDEC method)								350	A
Maximum Forward Voltage Drop per Bridge Element at 12.5A D.C.								1.05	V
Maximum DC Reverse Current Ta=25°C								10	µA
at Rated DC Blocking Voltage Ta=125°C								500	µA
Typical Junction Capacitance (Note 1)								85	PF
Typical Thermal Resistance R _{jc} (Note 2)								2.2	°C/W
Operating Temperature Range, T _J								-55 — +150	°C
Storage Temperature Range, T _{STG}								-55 — +150	°C

NOTES:

1. Measured at 1.0MHz and applied reverse voltage of 4.0V DC.
2. Thermal Resistance from Junction to Case with device mounted on 300mm x 300mm x 1.6mm Cu Plate Heatsink.

RATING AND CHARACTERISTIC CURVES (GBU25005 THRU GBU2510)

FIG.1-TYPICAL FORWARD CURRENT DERATING CURVE

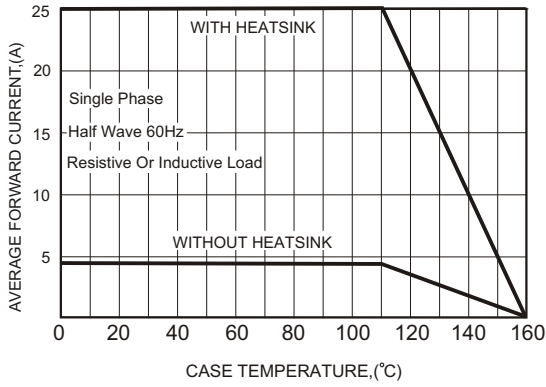

FIG.2-MAXIMUM NON-REPETITIVE FORWARD SURGE CURRENT

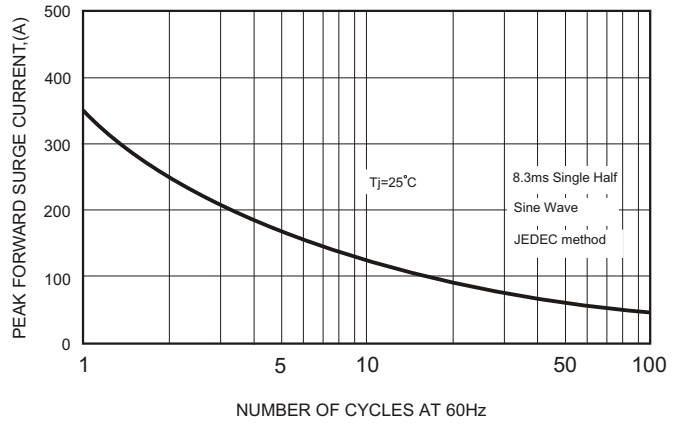

FIG.3-TYPICAL FORWARD CHARACTERISTICS

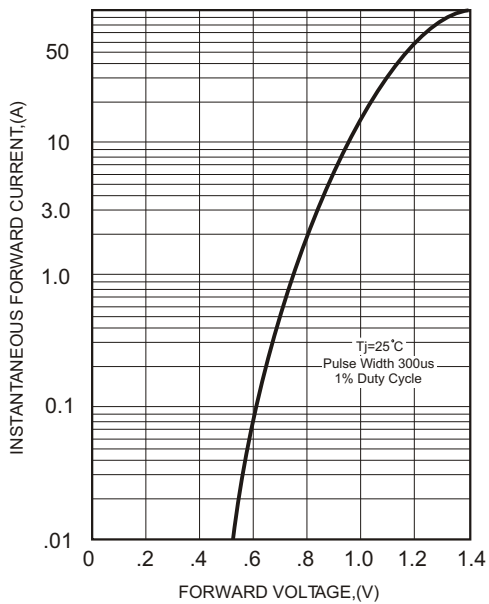

FIG.4-TYPICAL REVERSE CHARACTERISTICS

