

Product Summary

$V_{(BR)DSS}$	$R_{DS(on)TYP}$	I_D
-30V	25mΩ@-4.5V	-10A
	36mΩ@-2.5V	



合肥矽普半导体

Siliup Semiconductor Technology Co., Ltd

技术 品质 服务

www.siliup.com

Feature

- Fast switching speed
- Low On-Resistance
- 100% Single Pulse avalanche energy Test

Applications

- DC-DC Converters.
- Power Management

Package

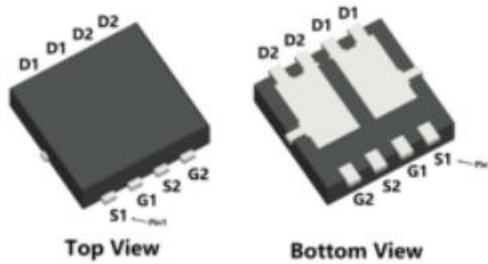

PDFN3X3-8L

Circuit diagram

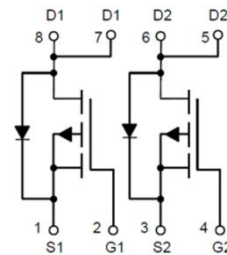

Marking

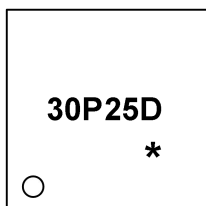

30P25D :Device Code
* :Month Code

Order Information

Device	Package	Unit/Tape
SP30P25DNJ	PDFN3X3-8L	5000

Absolute maximum ratings (Ta=25°C, unless otherwise noted)

Parameter	Symbol	Rating	Unit
Drain-Source Voltage	V_{DSS}	-30	V
Gate-Source Voltage	V_{GSS}	± 20	V
Continuous Drain Current (Tc=25°C)	I_D	-10	A
Continuous Drain Current (Tc=100°C)	I_D	-7	A
Pulse Drain Current Tested	I_{DM}	-40	A
Single Pulse Avalanche Energy ¹	E_{AS}	36	mJ
Power Dissipation (Tc=25°C)	P_D	16	W
Thermal Resistance Junction-to-Case	$R_{\theta JC}$	7.8	°C/W
Storage Temperature Range	T_{STG}	-55 to 150	°C
Operating Junction Temperature Range	T_J	-55 to 150	°C

Electrical characteristics (Ta=25°C, unless otherwise noted)

Parameter	Symbol	Conditions	Min.	Typ.	Max.	Unit
Static Characteristics						
Drain-Source Breakdown Voltage	BV_{DSS}	$V_{GS}=0V, I_D=-250\mu A$	-30	-	-	V
Drain-Source Leakage Current	I_{DSS}	$V_{DS}=-24V, V_{GS}=0V, T_J=25^\circ C$	-	-	-1	μA
Gate-Source Leakage Current	I_{GSS}	$V_{GS}=\pm 20V, V_{DS}=0V$	-	-	± 100	nA
Gate Threshold Voltage	$V_{GS(th)}$	$V_{GS}=V_{DS}, I_D=-250\mu A$	-1.0	-1.5	-2.5	V
Static Drain-Source On-Resistance	$R_{DS(on)}$	$V_{GS}=-10V, I_D=-4A$	-	25	32	m Ω
		$V_{GS}=-4.5V, I_D=-2A$	-	36	45	
Dynamic characteristics						
Input Capacitance	C_{iss}	$V_{DS}=-15V, V_{GS}=0V, f=1MHz$	-	850	-	pF
Output Capacitance	C_{oss}		-	116	-	
Reverse Transfer Capacitance	C_{rss}		-	112	-	
Total Gate Charge	Q_g	$V_{DS}=-15V, V_{GS}=-10V, I_D=-6.5A$	-	13	-	nC
Gate-Source Charge	Q_{gs}		-	2.6	-	
Gate-Drain Charge	Q_{gd}		-	2.2	-	
Switching Characteristics						
Turn-On Delay Time	$T_{d(on)}$	$V_{DD}=-15V, V_{GS}=-10V, R_G=3\Omega, I_D=-4A$	-	7.5	-	nS
Rise Time	T_r		-	5.5	-	
Turn-Off Delay Time	$T_{d(off)}$		-	19	-	
Fall Time	T_f		-	7	-	
Diode Characteristics						
Diode Forward Voltage	V_{SD}	$V_{GS}=0V, I_S=-1A, T_J=25^\circ C$	-	-	-1.2	V
Maximum Body-Diode Continuous Current	I_S		-	-	-10	A
Reverse recover time	T_{rr}	$I_S=-5A, di/dt=-100A/\mu s, T_J=25^\circ C$	-	0.9	-	nS
Reverse recovery charge	Q_{rr}		-	7	-	nC

Note:

1. The EAS test condition is $V_{DD}=-15V, V_G=-10V, L=0.5mH, R_G=25\Omega$

Typical Characteristics

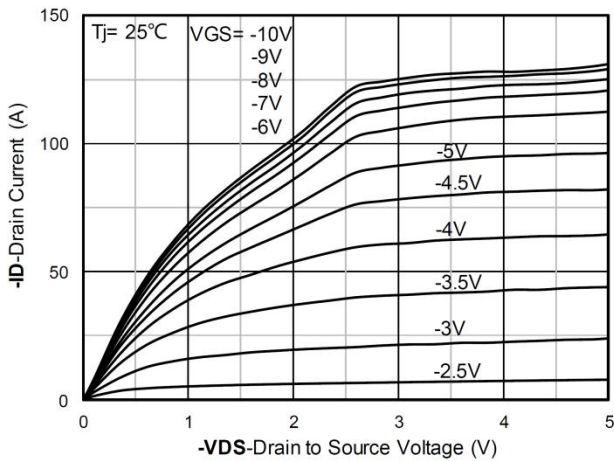

Output Characteristics

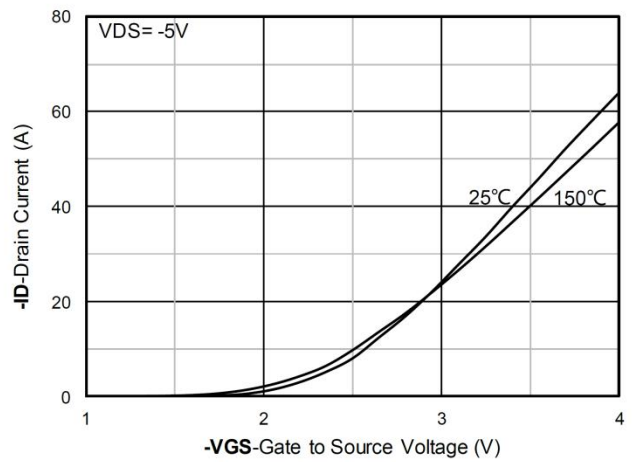

Transfer Characteristics

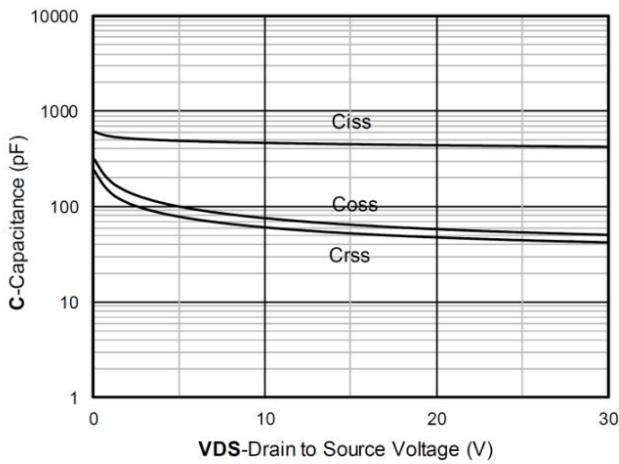

Capacitance Characteristics

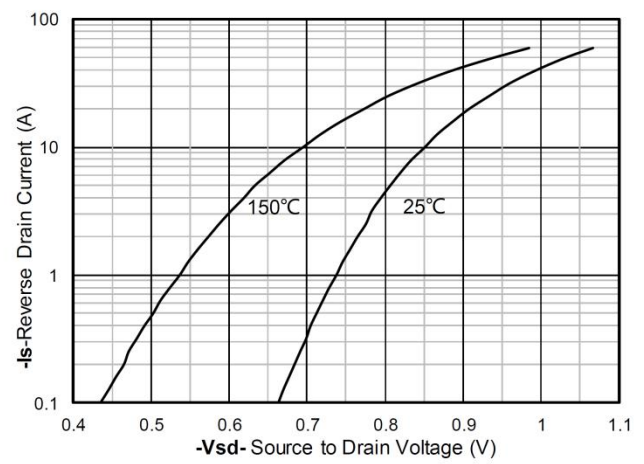

Forward characteristics of reverse diode

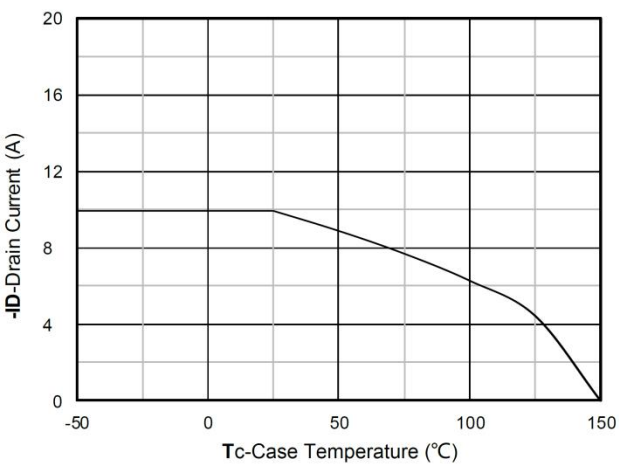

Current dissipation

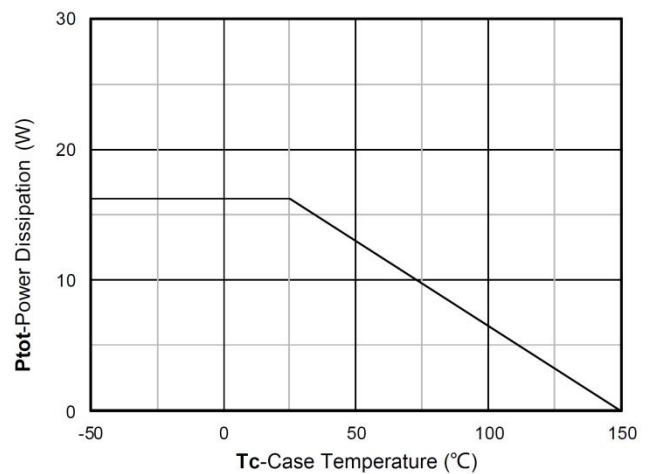

Power dissipation

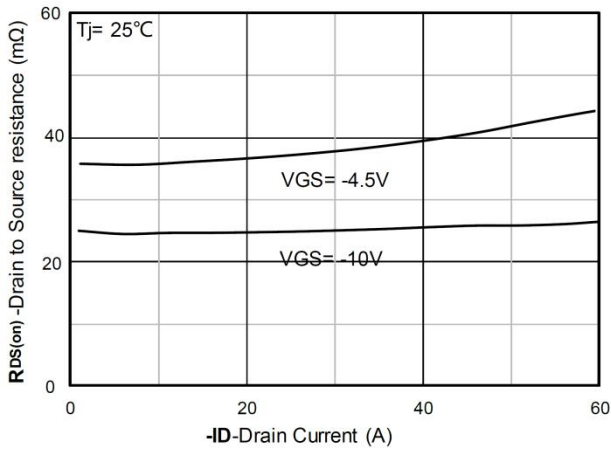

RDS(on) VS Drain Current

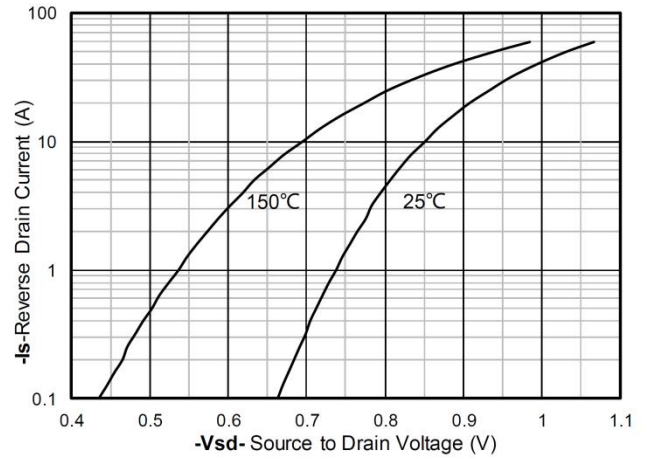

Forward characteristics of reverse diode

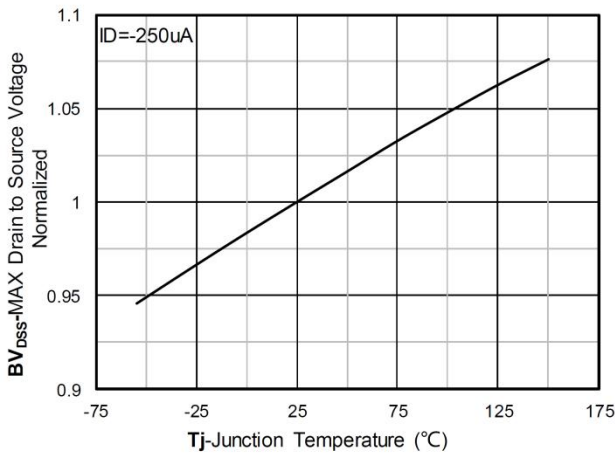

Normalized breakdown voltage

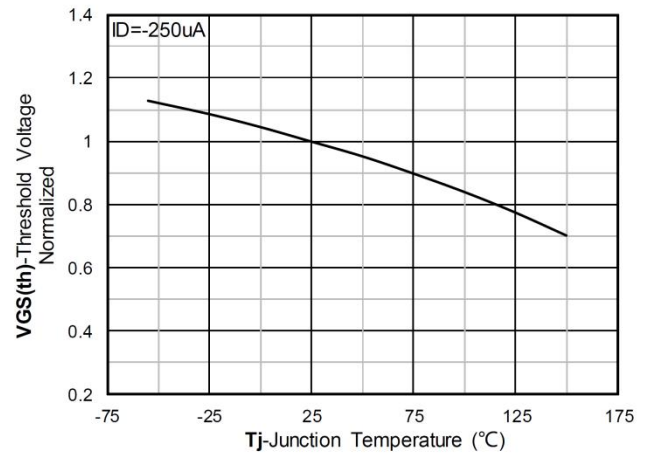

Normalized Threshold voltage

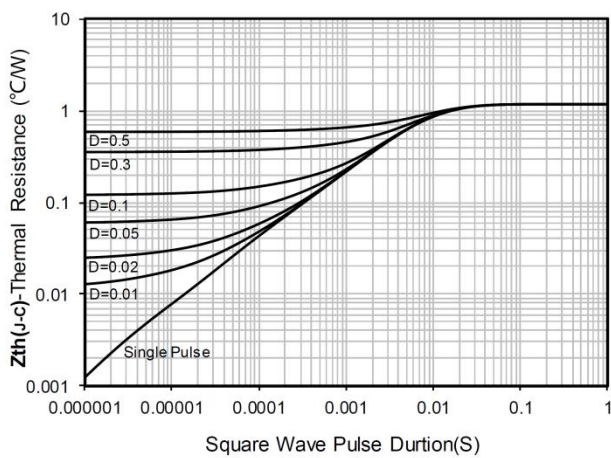

Maximum Transient Thermal Impedance

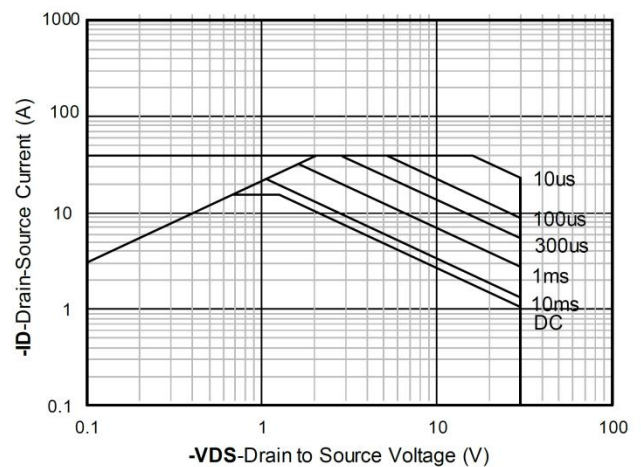

Safe Operation Area

PDFN3X3-8L Package Information

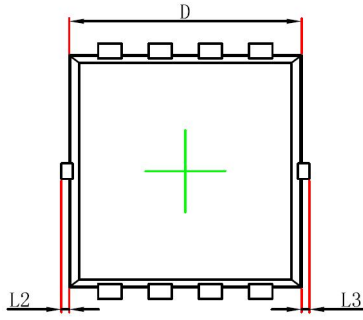

Top View
[顶视图]

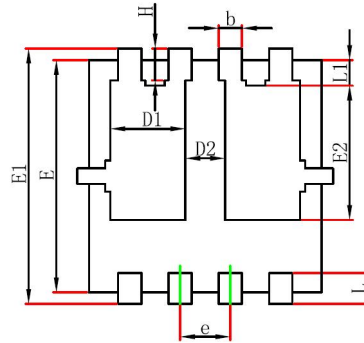

Bottom View
[背视图]

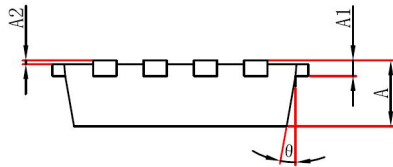

Side View
[侧视图]

Symbol	Dimensions In Millimeters		Dimensions In Inches	
	Min.	Max.	Min.	Max.
A	0.650	0.850	0.026	0.033
A1	0.152 REF.		0.006 REF.	
A2	0~0.05		0~0.002	
D	2.900	3.100	0.114	0.122
D1	0.935	1.135	0.037	0.045
D2	0.280	0.480	0.011	0.019
E	2.900	3.100	0.114	0.122
E1	3.150	3.450	0.124	0.136
E2	1.535	1.935	0.060	0.076
b	0.200	0.400	0.008	0.016
e	0.550	0.750	0.022	0.030
L	0.300	0.500	0.012	0.020
L1	0.180	0.480	0.007	0.019
L2	0~0.100		0~0.004	
L3	0~0.100		0~0.004	
H	0.315	0.515	0.012	0.020
θ	9°	13°	9°	13°