

Features

- For AF driver and output stages
- High collector current
- Low collector-emitter saturation voltage

Equivalent Circuit

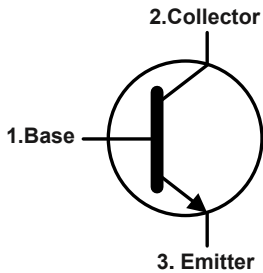

SOT-89

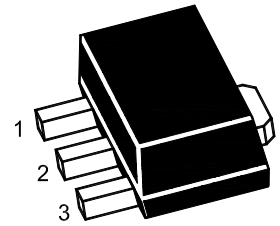

1.Base 2.Collector 3. Emitter

Marking Code :

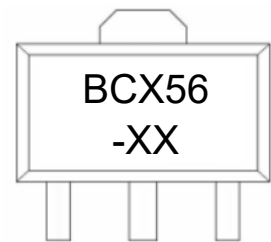

XX: 10/16

Absolute Maximum Ratings

Ratings at 25°C ambient temperature unless otherwise specified.

Parameter	Symbol	Value	Unit
Collector Base Voltage	V_{CBO}	100	V
Collector Emitter Voltage	V_{CEO}	80	V
Emitter Base Voltage	V_{EBO}	5	V
Collector Current	I_C	1	A
Peak Collector Current	I_{CM}	1.5	A
Maximum Power Dissipation	P_D	0.5 ^{Note1} 1.3 ^{Note2}	W
Junction Temperature	T_J	150	°C
Storage Temperature Range	T_{STG}	-65 to +150	°C

Note :1. Device mounted on an FR4 Printed-Circuit Board(PCB), single-sided copper, tin-plated and standard footprint.

2. Device mounted on an FR4 PCB, single-sided copper, tin-plated, mounting pad for collector 6 cm²



Electrical Characteristics (T_A=25°C)

Parameter	Symbol	Min.	Typ.	Max.	Unit
DC Current Gain at V _{CE} = 2 V, I _C = 5 mA	H _{FE}	40	--	--	--
at V _{CE} = 2 V, I _C = 150 mA		63	--	160	
BCX56SQ-10		100	--	250	
BCX56SQ-16		25	--	--	
Collector Base Cutoff Current at V _{CB} = 30V	I _{CBO}	--	--	100	nA
Emitter Base Cutoff Current at V _{EB} = 5 V	I _{EBO}	--	--	100	nA
Collector Base Breakdown Voltage at I _C = 100 μA	V _{(BR)CBO}	100	--	--	V
Collector Emitter Breakdown Voltage at I _C = 1 mA	V _{(BR)CEO}	80	--	--	V
Emitter Base Breakdown Voltage at I _E = 100 μA	V _{(BR)EBO}	5	--	--	V
Collector Emitter Saturation Voltage at I _C = 500 mA, I _B = 50 mA	V _{CE(sat)}	--	--	0.5	V
Base Emitter On Voltage at V _{CE} = 2 V, I _C = 500 mA	V _{BE}	--	--	1	V
Transition Frequency at V _{CE} = 5 V, I _C = 50 mA, f = 100 MHz	F _T	100	--	--	MHz
Output Capacitance at V _{CB} = 10 V, f = 1 MHz	C _{ob}	--	6	--	pF

Typical Characteristic Curves

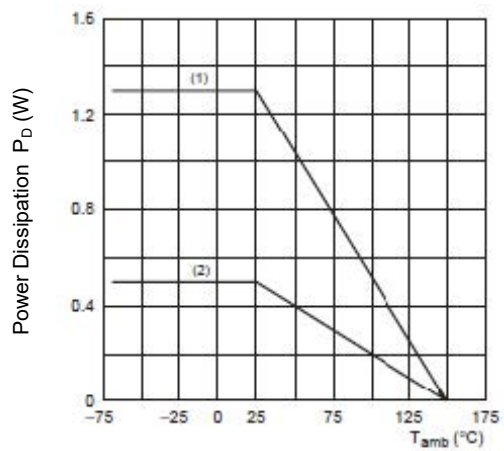
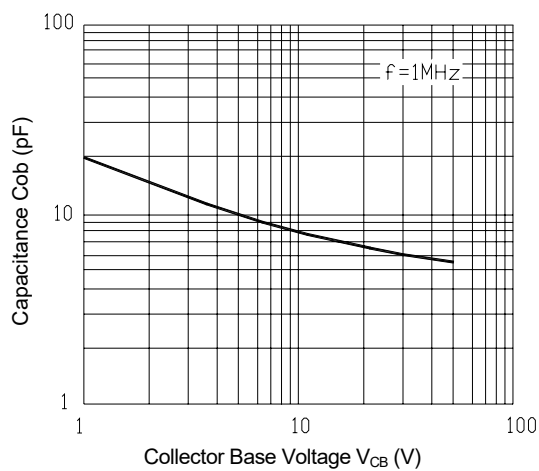
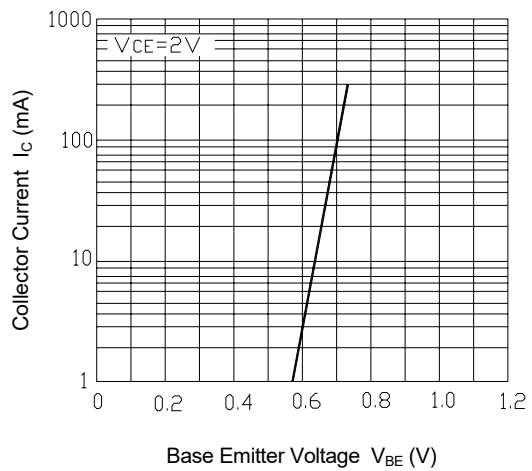
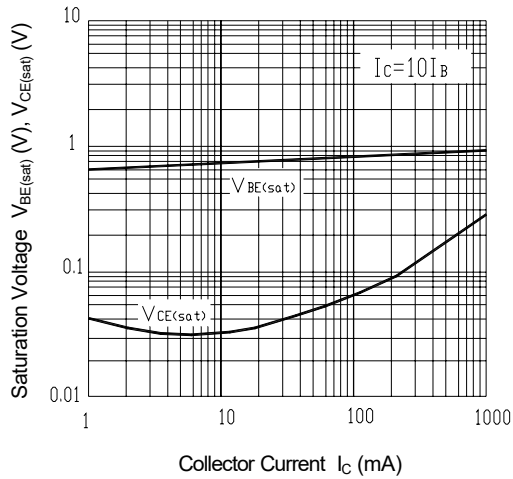
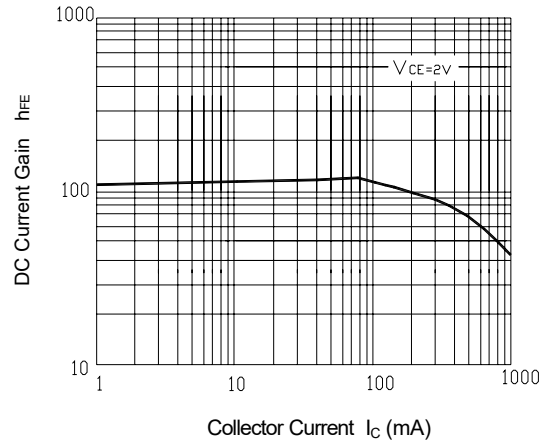
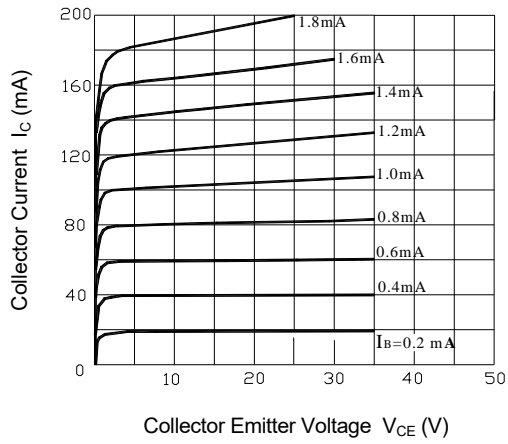

Ambient Temperature T_a ($^{\circ}\text{C}$)

Package Outline

SOT-89

Dimensions in mm

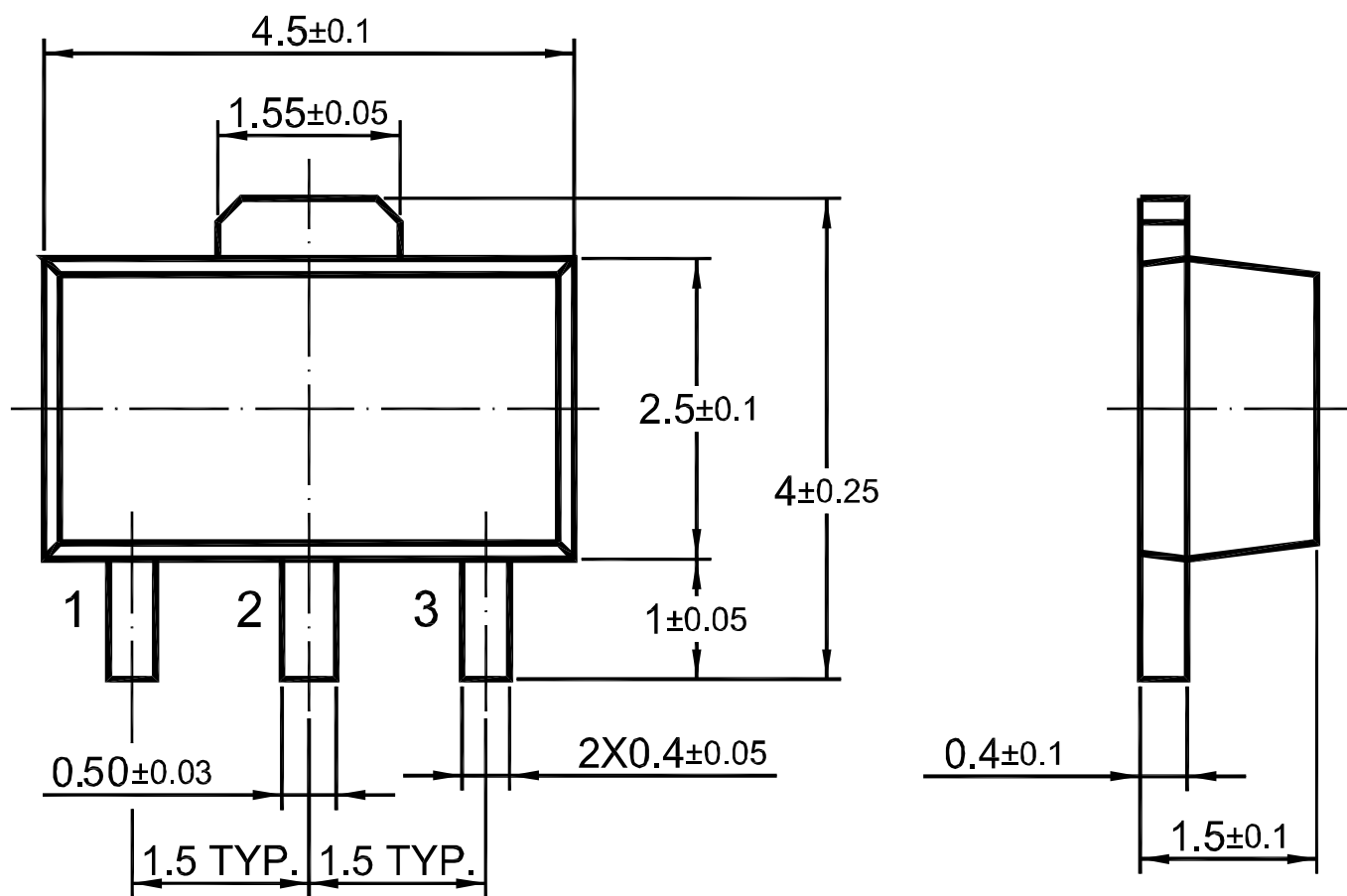

Ordering Information

Device	Package	Shipping
BCX56SQ	SOT-89	3,000PCS/Reel&13inches

Conditions of Soldering and Storage

◆ Recommended condition of reflow soldering



Recommended peak temperature is over 245 °C. If peak temperature is below 245 °C, you may adjust the following parameters:

- Time length of peak temperature (longer)
- Time length of soldering (longer)
- Thickness of solder paste (thicker)

◆ Conditions of hand soldering

- Temperature: 370 °C
- Time: 3s max.
- Times: one time

◆ Storage conditions

- **Temperature**
5 to 40 °C
- **Humidity**
30 to 80% RH
- **Recommended period**
One year after manufacturing

Package Specifications

- The method of packaging

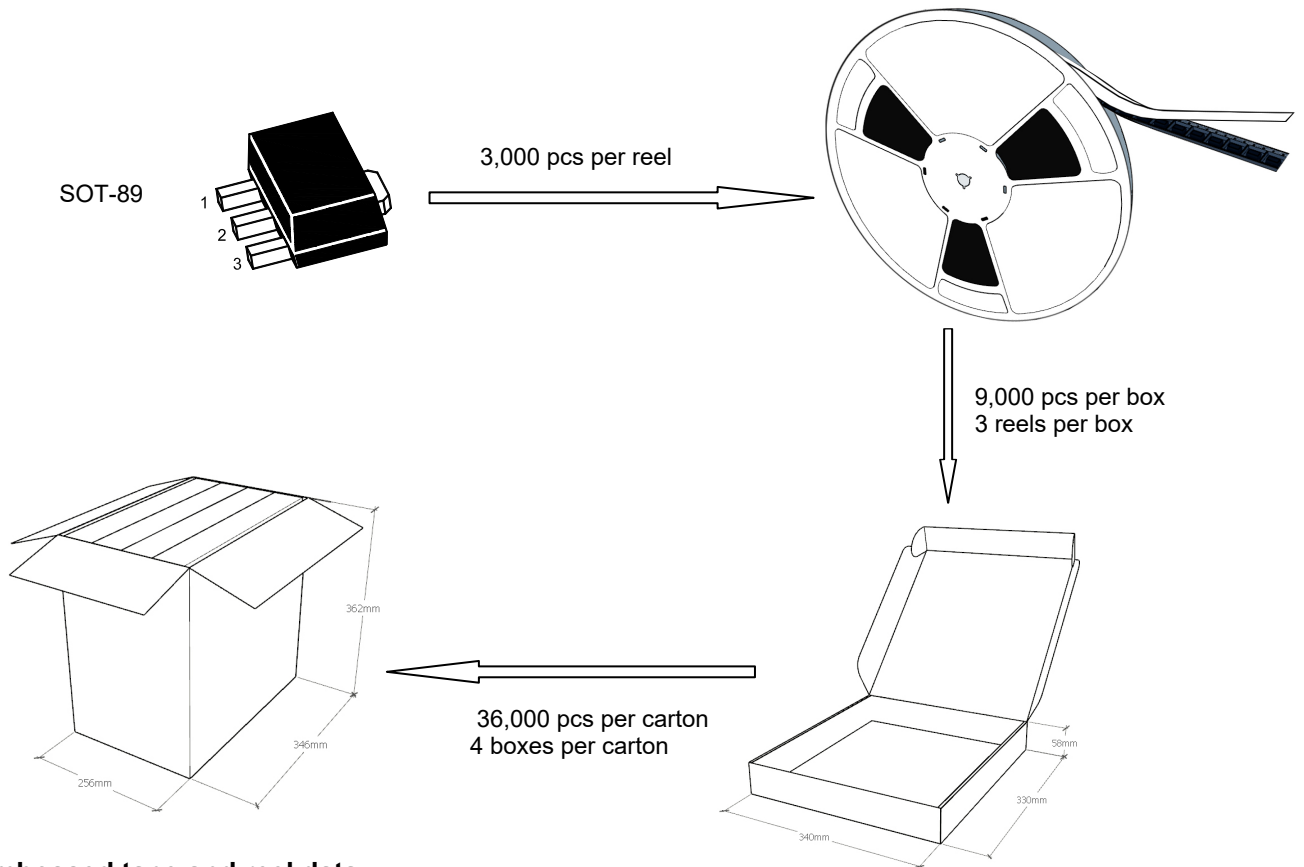

◆ Embossed tape and reel data

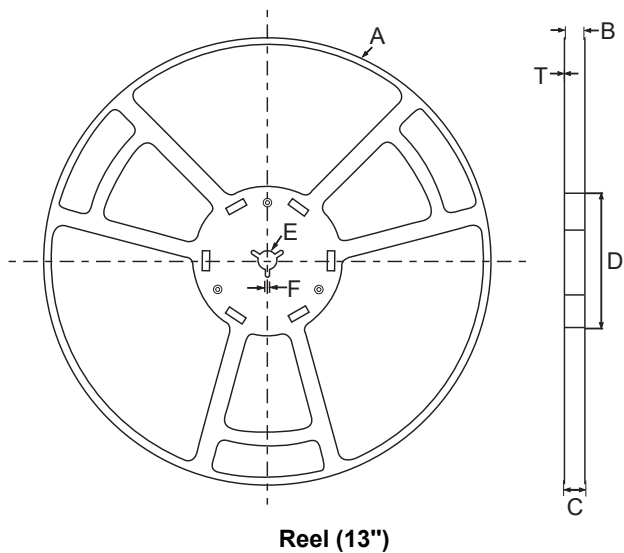

symbol	Value(unit:mm)
A	$\phi 330\pm 1$
B	12.7 ± 0.5
C	16.5 ± 0.3
D	$\phi 99.5\pm 0.5$
E	$\phi 13.6\pm 0.3$
F	2.8 ± 0.3
T	1.9 ± 0.2

