

General Description

The MAX25608 evaluation system (EV system) provides a proven design to evaluate the MAX25608 12 channel LED matrix manager. The EV system includes two instances of the MAX25608 each controlling 12 on-board LEDs connected in a series configuration. The MAX25601 boost-buck LED driver is included to drive the LEDs. The MAX3265PICO board and software GUI are included to communicate with the MAX25608 IC through the UART interface.

Features

- Two, 12 Channel Matrix Managers
- 24 On-Board White LEDs
- MAX25601 Boost-Buck LED Driver
- MAX32625PICO# Provides UART Communication to Control the Matrix Managers
- GUI for Easy Evaluation

[Ordering Information](#) appears at end of data sheet.

MAX25608 Evaluation System Board Photo

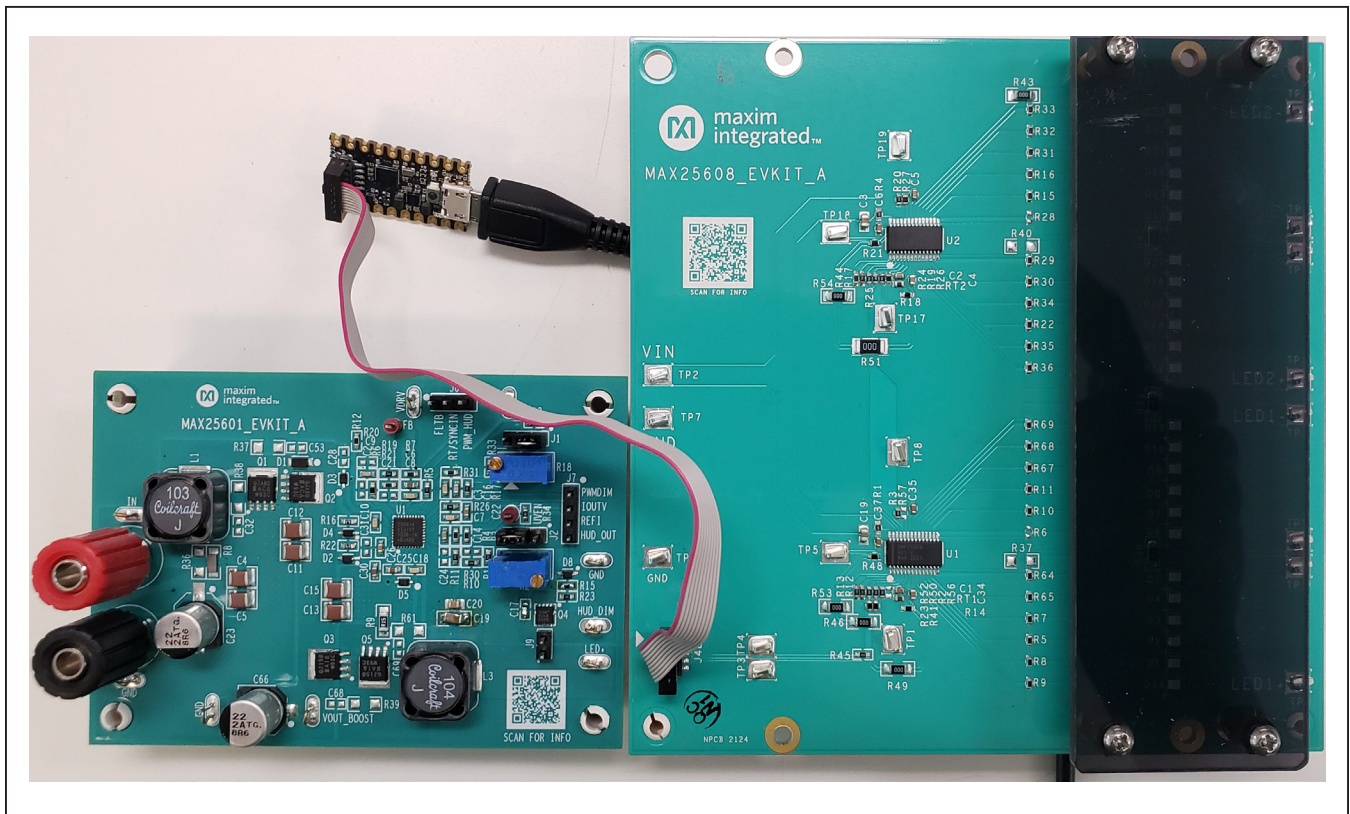

Quick Start

Required Equipment

- MAX25608 EV system
- MAX32625PICO# (included)
- Windows® 10 computer with GUI installed
- 12V, 5A power supply

Procedure

The EV system is fully assembled and tested. Use the following steps to verify board operation.

Caution: Do not turn on the power supply until all connections are made. Additional caution should be taken; the on-board LEDs are very bright when illuminated.

- 1) Connect the positive terminal of the +12V power supply to the VIN pad of the MAX25608 board.
- 2) Connect the ground terminal of the +12V power supply to the GND pad of the MAX25608 board.
- 3) Connect the positive terminal of the +12V power supply to the IN pad of the MAX25608 board.
- 4) Connect the ground terminal of the +12V power supply to the GND pad of the MAX25601 board.
- 5) Connect the LED+ pad of the MAX25601 board to the LED1+ pad of the MAX25608 board.

- 6) Connect the GND pad of the MAX25601 board to the LED1- pad of the MAX25608 board.
- 7) Connect the MAX32625PICO# to the MAX25608EV-SYS using the included ribbon cable.
- 8) Connect the MAX32625PICO# to the computer with the included USB cable.
- 9) If the GUI is not yet installed, install the GUI.
- 10) Run the GUI.
- 11) Click the **Connect** button and choose device 08 to communicate with the MAX25608 IC driving the LEDs connected between LED1+ and LED1-.
- 12) A separate current source needs to be used for driving the LEDs between LED2+ and LED2- pads. The MAX25608 IC device ID for this is 04.

Detailed Description

The MAX25608 evaluation system (EV system) provides a proven design to evaluate the MAX25608 12 channel LED matrix manager. The EV system includes two instances of the MAX25608 controlling 12 on-board LEDs connected in a series configuration. The MAX25601 boost-buck LED driver is also included to drive one of the strings of 12 LEDs. A separate current source is needed to drive the second set of LEDs connected between LED2+ and LED2-.

Table 1. MAX25601 Current Source Jumper Setting

JUMPER	SHUNT POSITION	DESCRIPTION
J1	1-2*	Connects DIM pin to the resistive divider from VCC. Varying this pin voltage from 0.2V to 3.2V changes the PWM duty from 0% to 100%. Set this pin to >3.5V for 100% duty in this Matrix Manager application.
	2-3	Connects DIM pin to GND.
	Open	Disconnects DIM from the voltage divider. Allows DIM to be driven by an external voltage source or PWM signal to drive the DIM pin.
J2	1-2	Connects VCC to the REF1 pin. LED current is at the maximum value in this configuration.
	2-3*	Connects REF1 to a voltage-divider from VCC to ground. Adjusting R2 allows programming the LED current from 0 to 1.4A. The LED current is set at 1A in the board.
	Open	Disconnects the REF1 pin of the device from the external voltage-divider on the VCC pin. Allows REF1 to be driven by an external voltage to set the LED current level.
J9	1-2	HUD dimming jumper.
	Open*	Disconnects HUD dimming. Default is Open.

Windows is a registered trademark and registered service mark of Microsoft Corporation.

Analog Dimming Control (ICTRL)

The MAX25601 current source board is set up for 1A LED current. This can be adjusted by adjusting the potentiometer R2. The current can be set to a maximum of 1.4A.

Pulse-Dimming Input (PWMDIM)

Typically for matrix manager applications, the LED driver PWM dimming is not used. Therefore, the default J1 position across pins 1-2 in the MAX25601 board is sufficient. The matrix managers implement any desired PWM dimming on a per LED basis through the UART interface.

Graphical User Interface (GUI)

The MAX25608 EV system comes with a GUI to facilitate evaluation of the MAX25608 matrix manager device. Once the board is powered up and the PICO board is connected to the EV kit, click the **Connect** button. The **Device0** and **Device1** fields should populate with the appropriate device IDs of the MAX25608 devices.

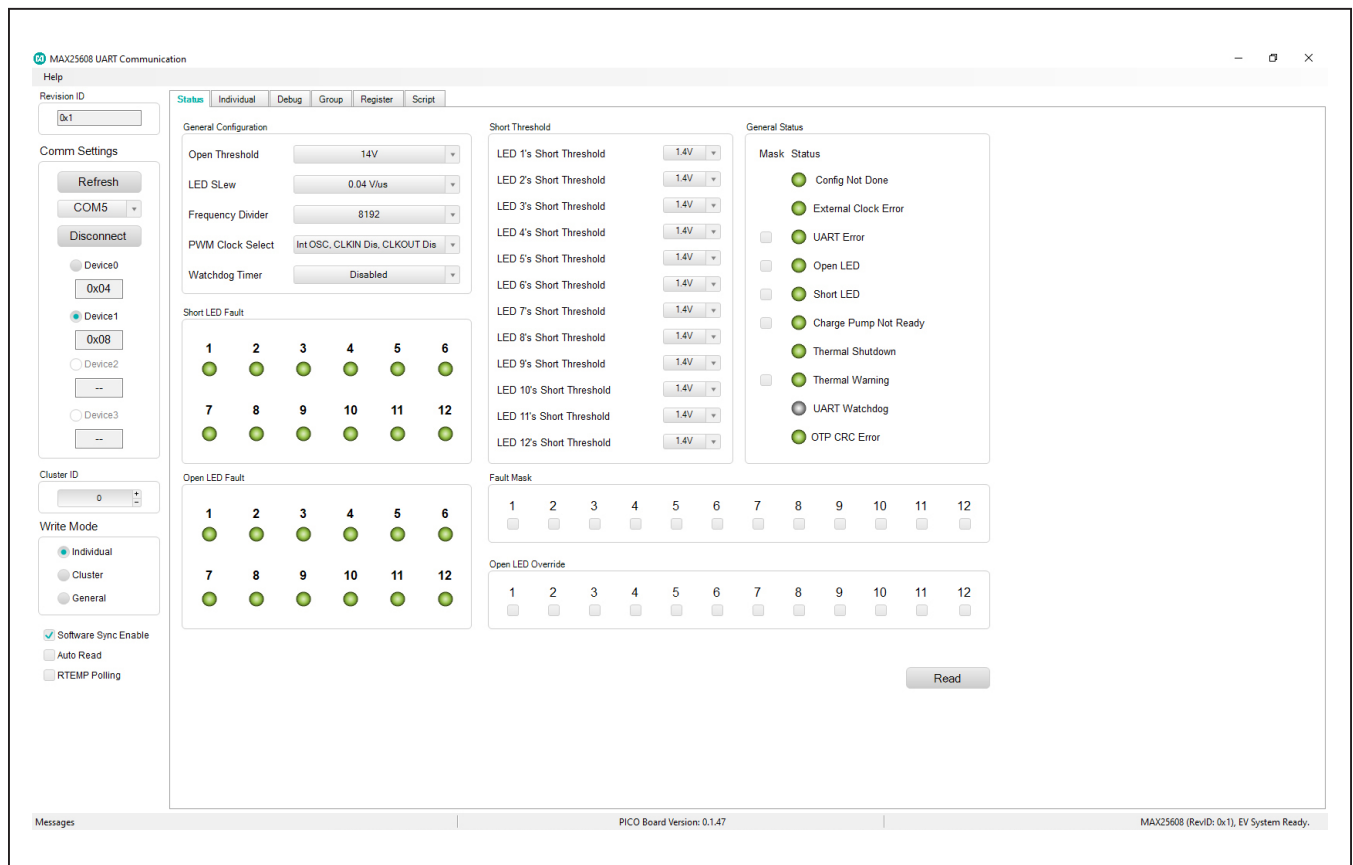

Figure 1. MAX25608 EV System Graphical User Interface

Individual Dimming and Group Dimming

Individual channel PWM dimming can be controlled on the **Individual** tab. Group PWM dimming can be controlled on the **Group** tab. LEDs can be grouped in Group A and B. The SW_GO_EN bit must be set to 1 before any switch programming can occur. This is the **Software Sync Enable** button in the GUI.

Slew Rate Control

The switches across the LEDs can be turned ON and OFF in a slew rate controlled manner. This allows the LED current to have minimum overshoots and undershoots and improves the EMI performance. The LED slew pull-down menu shows all the settings for the slew rate control.

Note: Each time the slew rate control is changed, the SW_GO_EN bit needs to be set to zero. This is applicable for the change in the **Open LED** and **Short LED** threshold settings as well.

Register Map

The full register map is available on the **Register** tab. This tab also supports read and write commands for each register.

Scripting

The MAX25608 GUI features the ability to run the scripts which contain UART write commands and delay commands. This allows for easily creating and testing lighting animations. Click the **Load Script** button to open a file navigator and select the desired **.json** file. The name of the script file is populated in the **Script Name** field. Click the **Run Script** and the commands in the script file, begin executing in sequence until the script is complete.

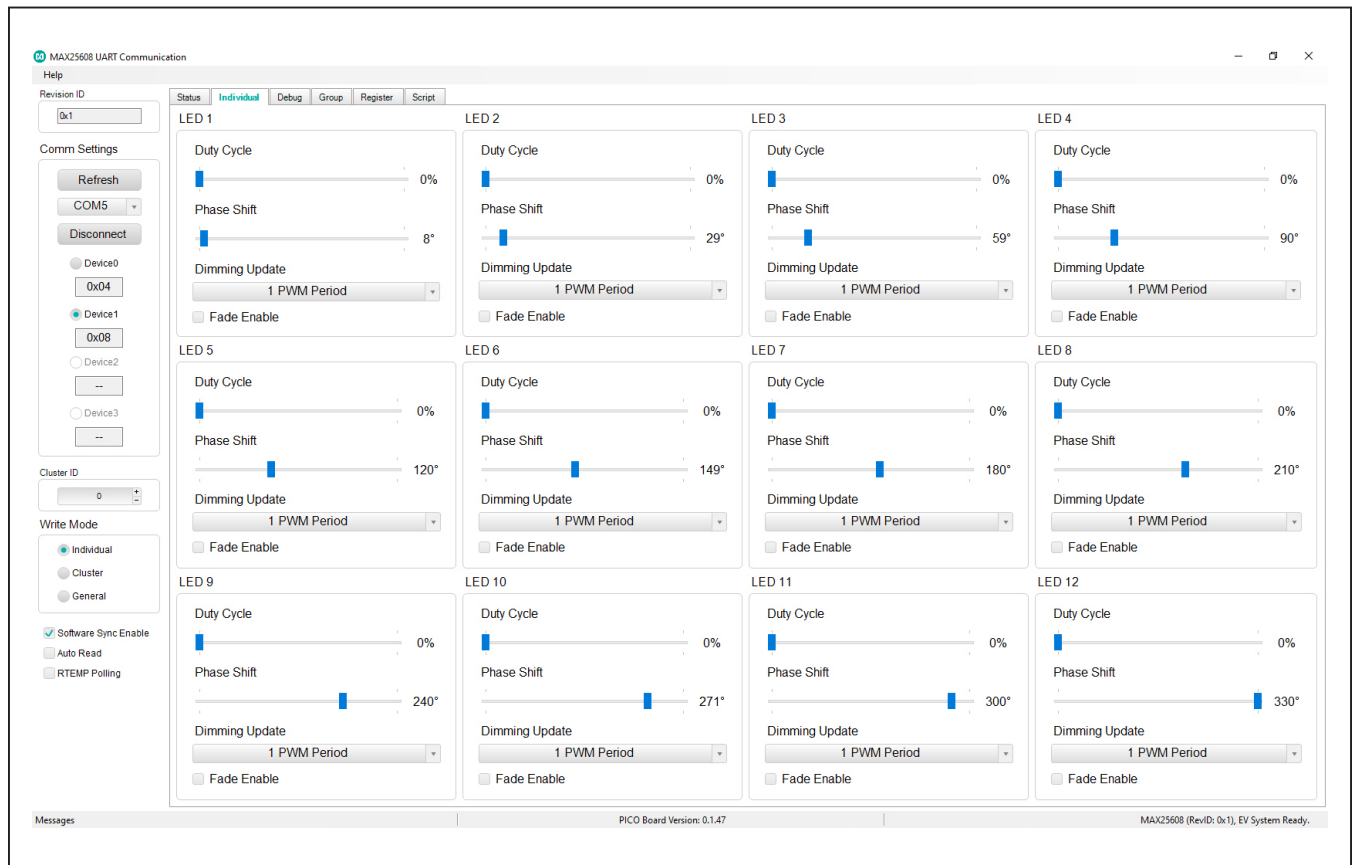

Figure 2. Individual Tab

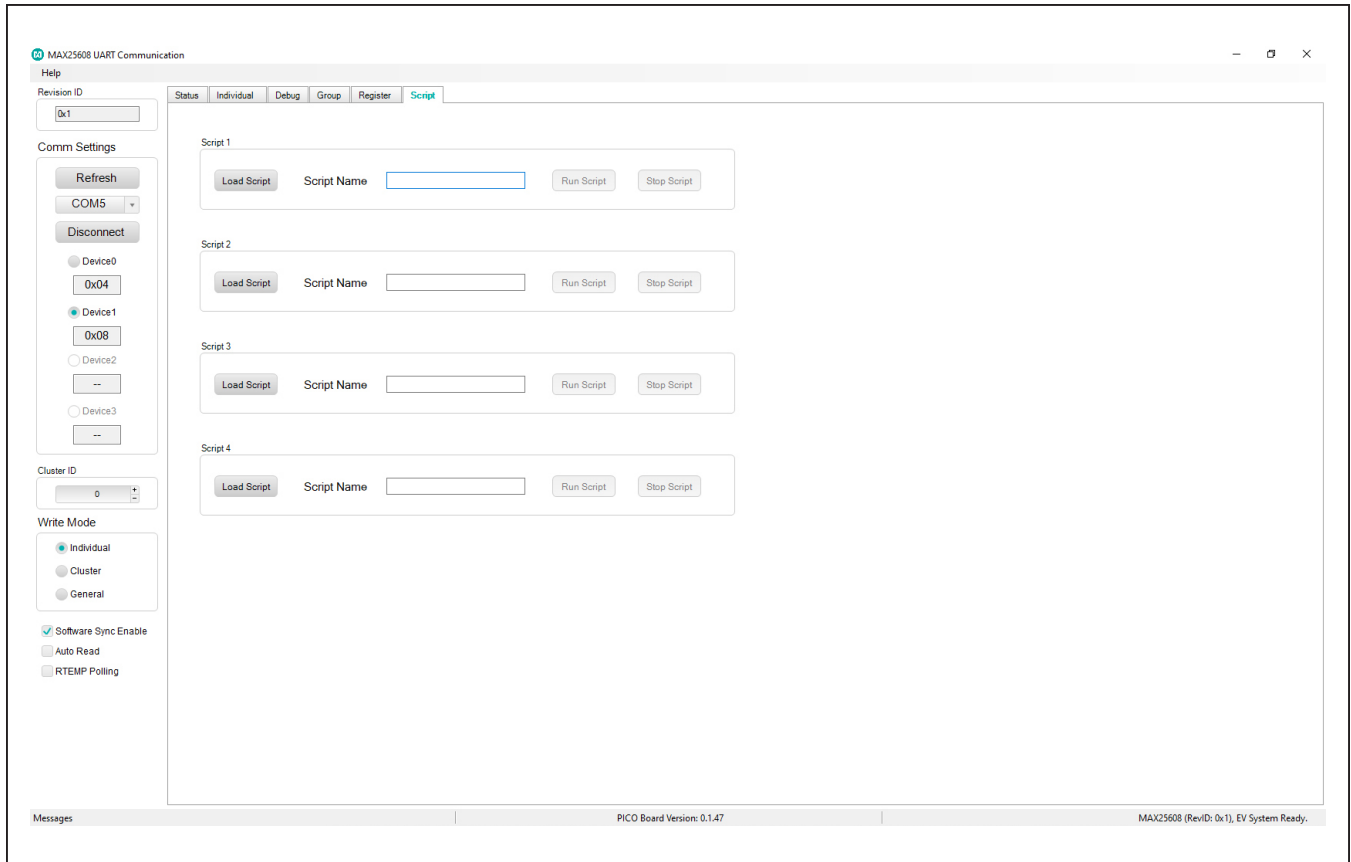

Figure 3. Scripting Tab

Ordering Information

PART	TYPE
MAX25608EVSYS#	EV System

#Denotes RoHS compliance.

MAX25608 EV Kit Bill of Materials

ITEM	REF_DES	DNI/DNP	QTY	MFG PART #	MANUFACTURER	VALUE	DESCRIPTION	COMMENTS
1	C1, C2, C5, C6, C35, C37	-	6	GCM188R71H104KA12; GCM188R71H104K; CGA3E2X7R1H104K080AA; CGA3E2X7R1H104K080AD; CL10B104KB8WPN	MURATA;MURATA;TDK; TDK;SAMSUNG	0.1UF	CAP; SMT (0603); 0.1UF; 10%; 50V; X7R; CERAMIC	
2	C3, C19	-	2	GRM21BR71H105KA12; CL21B105KBFNNN; C2012X7R1H105K085AC; UMK212B7105KG	MURATA;SAMSUNG ELECTRONICS; TDK; TAIYO YUDEN	1UF	CAP; SMT (0805); 1UF; 10%; 50V; X7R; CERAMIC	
3	C4, C34	-	2	C1608X5R1E225K; TMK107ABJ225KA; TMK107BJ225KA; GRM188R61E225KA12	TDK;TAIYO YUDEN; TAIYO YUDEN;MURATA	2.2UF	CAP; SMT (0603); 2.2UF; 10%; 25V; X5R; CERAMIC	
4	COVER1	-	1	80-100052	MAXIM	80-100052	COVER; LED_COVER_MAX25608_EVKIT; 5.00 X 1.58 IN	
5	D1-D23, D34	-	24	KW CELNM1.TG-Z5NF6 -EBVFFCBB46-15B3	OSRAM	KW CELNM1.TG-Z5NF6 -EBVFFCBB46-15B3	DIODE; LED; WHITE; SMT; VF=3V; IF=1A;	
6	J48	-	1	FTSH-105-01-L-DV-K	SAMTEC	FTSH-105-01-L-DV-K	CONNECTOR; MALE; SMT; 0.05 (1.27MM) SMT MICRO HEADER; STRAIGHT; 10PINS	
7	R1-R4, R19, R20, R24, R25, R50, R52	-	10	CRCW06030000ZS; MCR03EZPJ000; ERJ-3GEY0R00; CRO603AJ/-000ELF	VISHAY; ROHM SEMICONDUCTOR; PANASONIC;BOURNS	0	RES; SMT (0603); 0; JUMPER; JUMPER; 0.1000W	
8	R5, R7-R11, R15, R16, R22, R29-R36, R64, R65, R67-R69, R6, R28	-	24	MCR03EZPFX2002; ERJ-3EKF2002; CRO603-FX-2002ELF; CRCW060320K0FK	ROHM;PANASONIC; BOURNS;VISHAY DALE	20K	RES; SMT (0603); 20K; 1%; +/- 100PPM/DEGC;0.1000W	(R6,R28:DNP)
9	R12, R13, R17	-	3	CRCW06031K05FK	VISHAY DALE	1.05K	RES; SMT (0603); 1.05K; 1%; +/-100PPM/DEGC;0.1000W	
10	R14, R18	-	2	CRCW0603432RFX	VISHAY DALE	432	RES; SMT (0603); 432; 1%; +/-100PPM/DEGC;0.1000W	
11	R21, R23, R41, R48	-	4	CRCW060310K0FK; ERJ-3EKF1002; AC0603FR-0710KL; RMCFO603FT10K0	VISHAY DALE; PANASONIC;YAGEO	10K	RES; SMT (0603); 10K; 1%; +/-100PPM/DEGC;0.1000W	
12	R26, R27	-	2	CRCW060349R9FK	VISHAY DALE	49.9	RES; SMT (0603); 49.9; 1%; +/-100PPM/DEGC;0.1000W	
13	R38, R39, R42, R43, R46, R49, R53, R54	-	8	CRCW12060000Z0; RMCF1206ZTOR00	VISHAY DALE; STACKPOLE ELECTRONICS INC	0	RES; SMT (1206); 0; JUMPER; JUMPER; 0.2500W	
14	R44	-	1	ERJ-3EKF5360	PANASONIC	536	RES; SMT (0603); 536; 1%; +/-100PPM/DEGC;0.1000W	
15	R45	-	1	CRCW06030000Z0	VISHAY DALE	0	RES; SMT (0603); 0; JUMPER; JUMPER; 0.1000W	

MAX25608 EV Kit Bill of Materials (continued)

ITEM	REF_DES	DNI/DNP	QTY	MFG PART #	MANUFACTURER	VALUE	DESCRIPTION	COMMENTS
16	R51	-	1	CRCW20100000ZS	VISHAY DALE	0	RES; SMT (2010); 0; JUMPER; JUMPER; 0.7500W	
17	RT1, RT2	-	2	NTCG163JH103HT1	TDK	10K	THERMISTOR; SMT (0603); 10K; TOL=+/-3%	
18	SPACER1-SPACER4	-	4	9032	KEYSTONE	9032	MACHINE FABRICATED; ROUND-THRU HOLE SPACER; NO THREAD; M3.5; 5/8IN; NYLON	
19	TP1-TP19	-	19	USE FOR COLD TEST: 5016	KEYSTONE	N/A	TEST POINT; SMT; PIN LENGTH=0.185IN; PIN WIDTH=0.135IN; PIN HEIGHT=0.09IN; SILVER; PHOSPHOR BRONZE WITH SILVER PLATE CONTACT	
20	U1, U2	-	2	MAX25608AUI/V+	MAXIM	MAX25608AUI/V+	EVKIT PART - IC; MNGR; 12 SWITCH HIGH BRIGHTNESS LED MATRIX MANAGER FOR AUTOMOTIVE FRONT LIGHTS; PACKAGE OUTLINE DRAWING: 21-0108; PACKAGE LAND PATTERN: 90-1000175; TSSOP28-EP	
21	PCB	-	1	MAX25608	MAXIM	PCB	PCB:MAX25608	-
22	COVER1	DNI	4	MCH_SO_F_HEX_4-40X3/8	GENERIC PART	N/A	STANDOFF; FEMALE-THREADED; HEX; 4-40; 3/8IN; ALUMINUM	
23	COVER1	DNI	4	4C25MXPS;9900;91772A106	MCMaster-CARR; KEYSTONE; MCMaster-CAR	N/A	MACHINE SCREW; PHILLIPS; PAN; 4-40; 1/4IN; 18-8 STAINLESS STEEL	
24	COVER1	DNI	4	PHILLIPS-PAN_4-40X1/2IN	GENERIC PART	N/A	MACHINE SCREW; PHILLIPS; PAN; 4-40; 1/2IN; 18-8 STAINLESS STEEL	
25	HS1	DNP	0	80-100053	MAXIM	80-100053	MACHINE FABRICATED; HSINK; HEAT SINK_MAX25608_EVKIT_P2; 127MMX80MMX8MM; ALUMINUM 6061-T6	
26	R37, R40	DNP	0	CRCW12060000Z0; RMC1206ZT0R00	VISHAY DALE; STACKPOLE ELECTRONICS INC	0	RES; SMT (1206); 0; JUMPER; JUMPER; 0.2500W	
27	R56, R57	DNP	0	CRCW060349R9FK	VISHAY DALE	49.9	RES; SMT (0603); 49.9; 1%; +/-100PPM/DEGC; 0.1000W	
TOTAL			132					

PACKOUT (These are purchased parts but not assembled on PCB and will be shipped with PCB)

ITEM	REF_DES	DNI/DNP	QTY	MFG PART #	MANUFACTURER	VALUE	DESCRIPTION	COMMENTS
1	U4	-	1	MAX32625PICO	MAXIM	MAX32625PICO	MODULE; BOARD; MAX32625PICO BOARD DESIGN FOR MAX32625 ARM CORTEX-M4F; BOARD; LAMINATED PLASTIC WITH COPPER CLAD; NOTE: SOCKETED FOOTPRINT USING BCS-110-L-S-TE CONNECTOR WITH MATING CONNECTOR TSW-110-07-F-S	
2	U5	-	1	MAX25601EVKIT#	MAXIM	MAX25601EVKIT#	MAX25601 EVKIT; Current source for MAX25608 Matrix manager	
TOTAL			134					

MAX25608 EV Kit Schematics

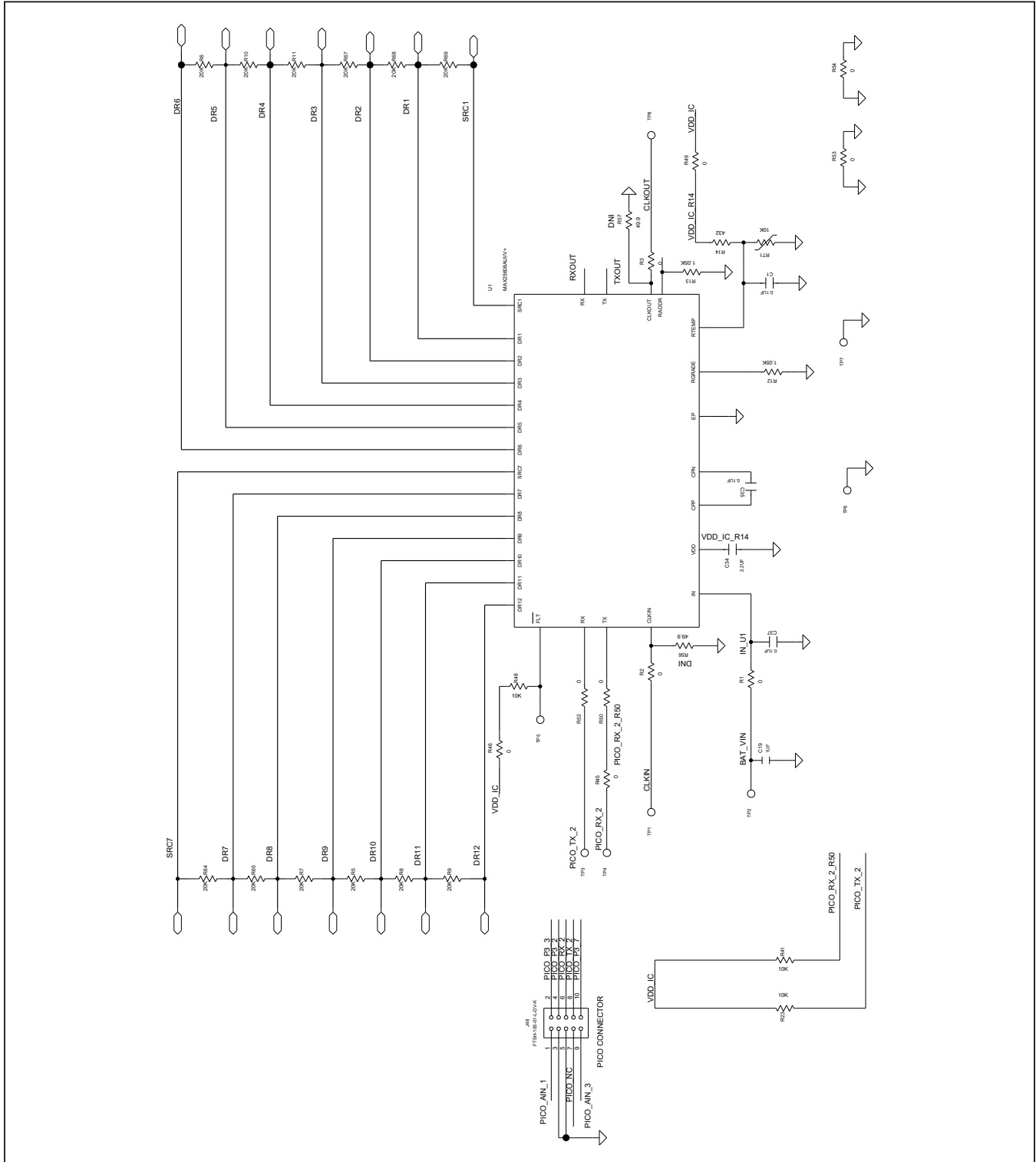

MAX25608 EV Kit Schematics (continued)

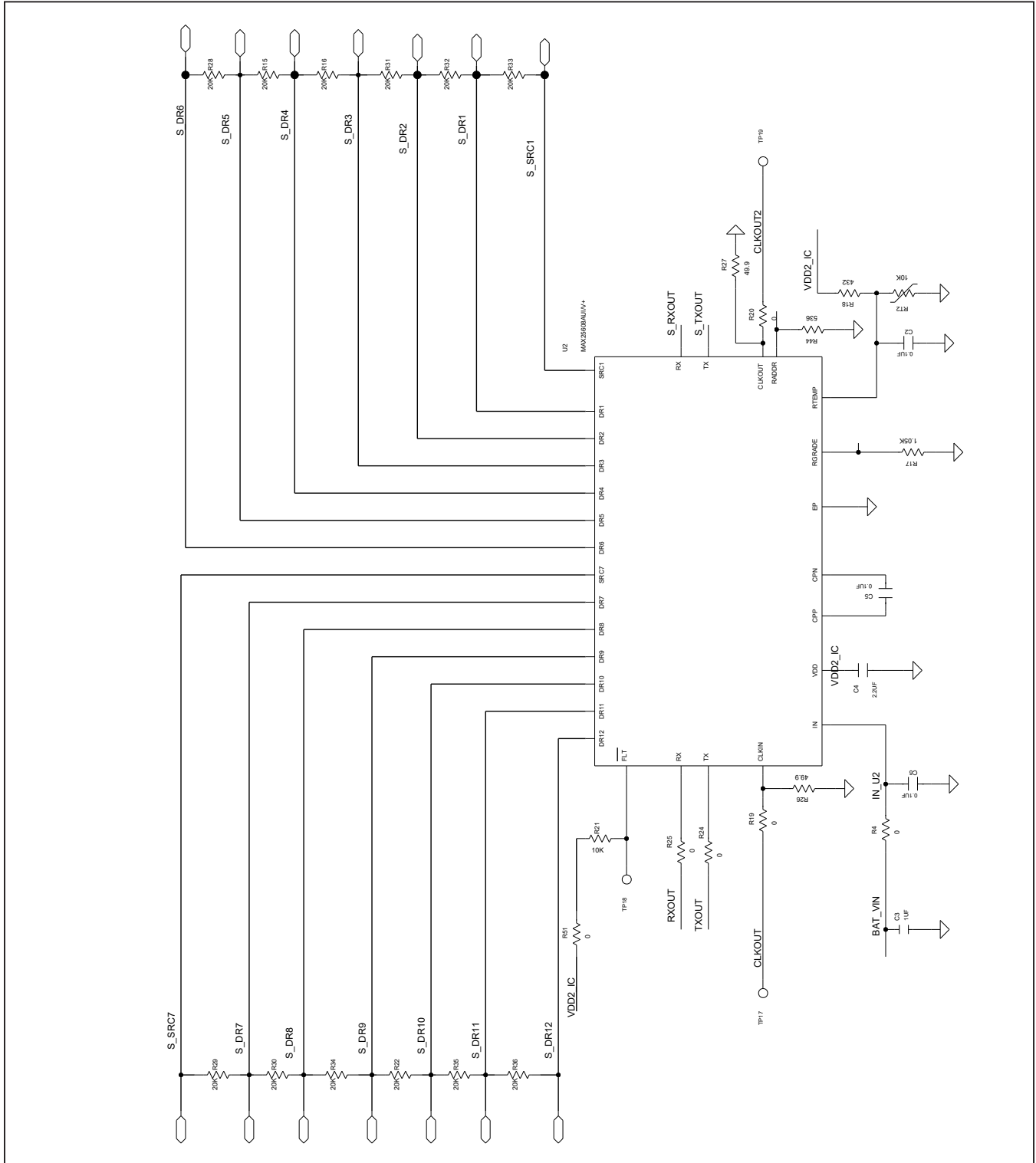

MAX25608 EV Kit Schematics (continued)

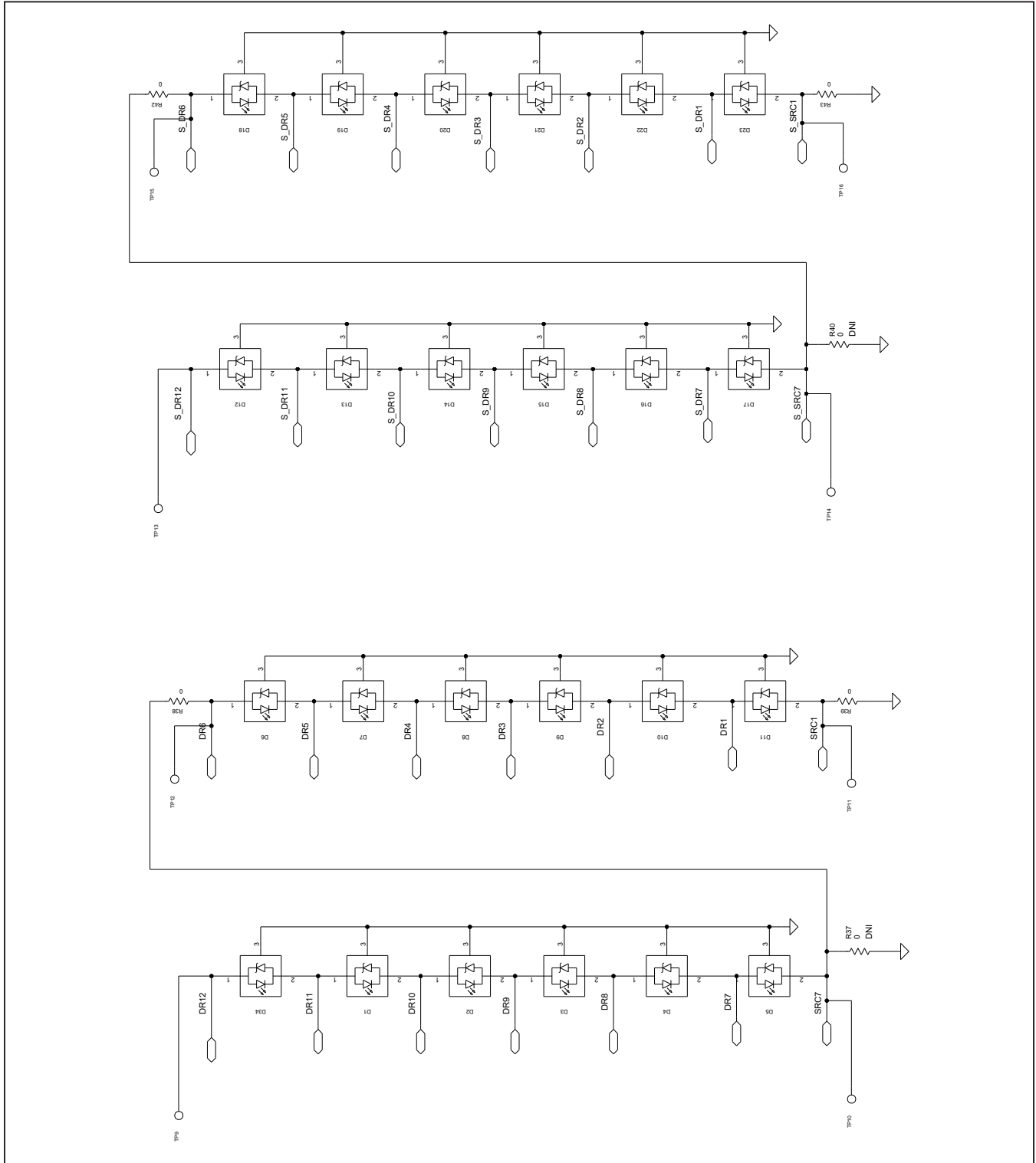

MAX25608 EV Kit PCB Layout Diagrams

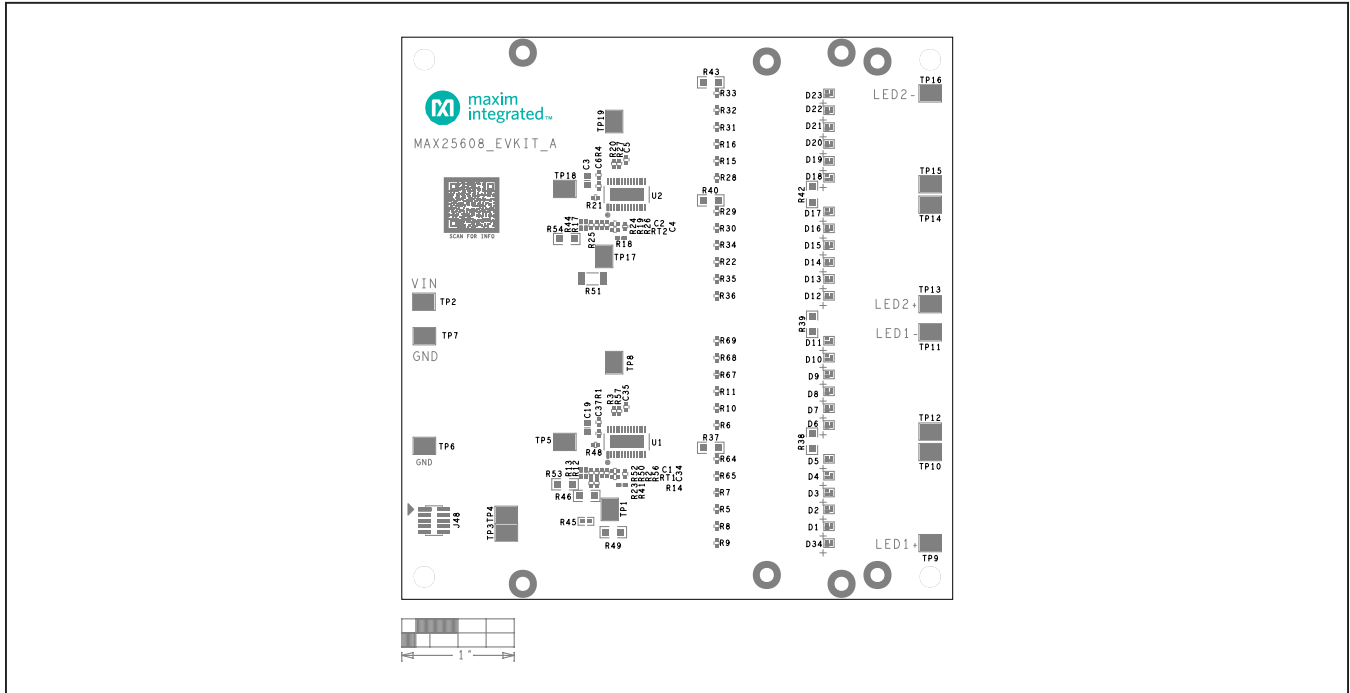

MAX25608 EV Kit Component Placement Guide—Top Silkscreen

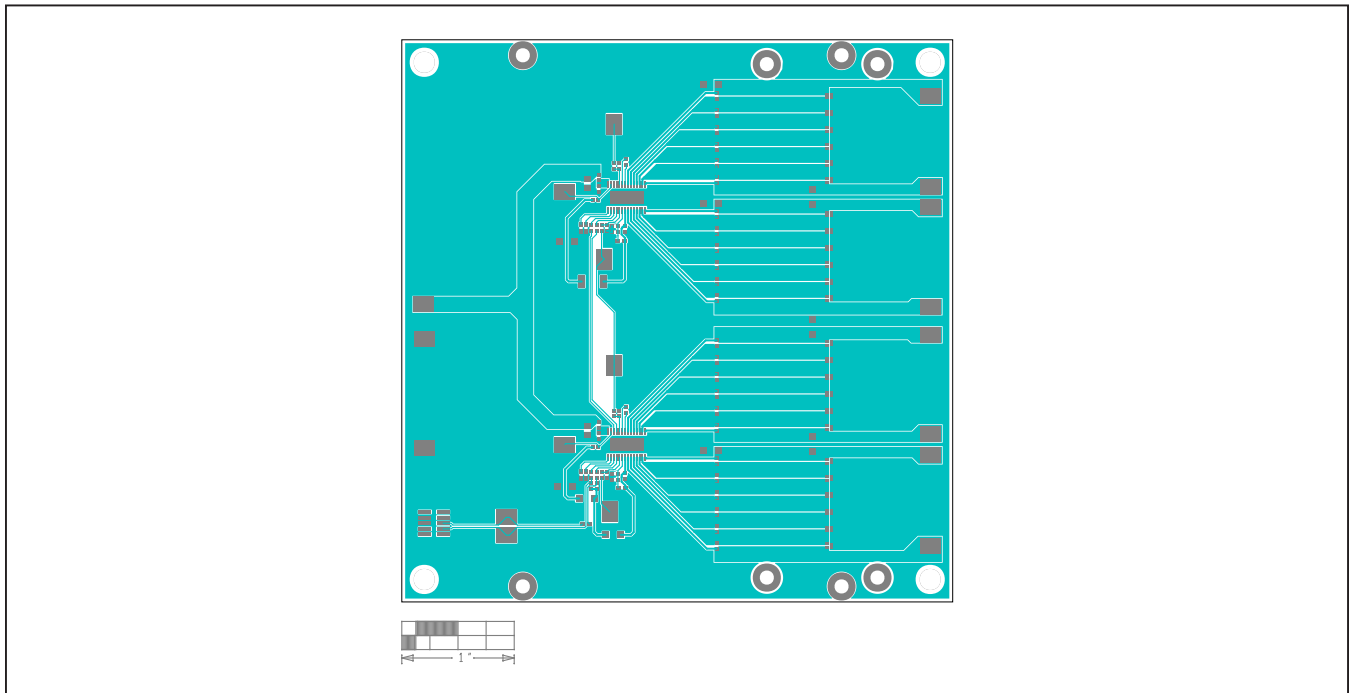

MAX25608 EV Kit PCB Layout—Top View

MAX25608 EV Kit PCB Layout Diagrams (continued)

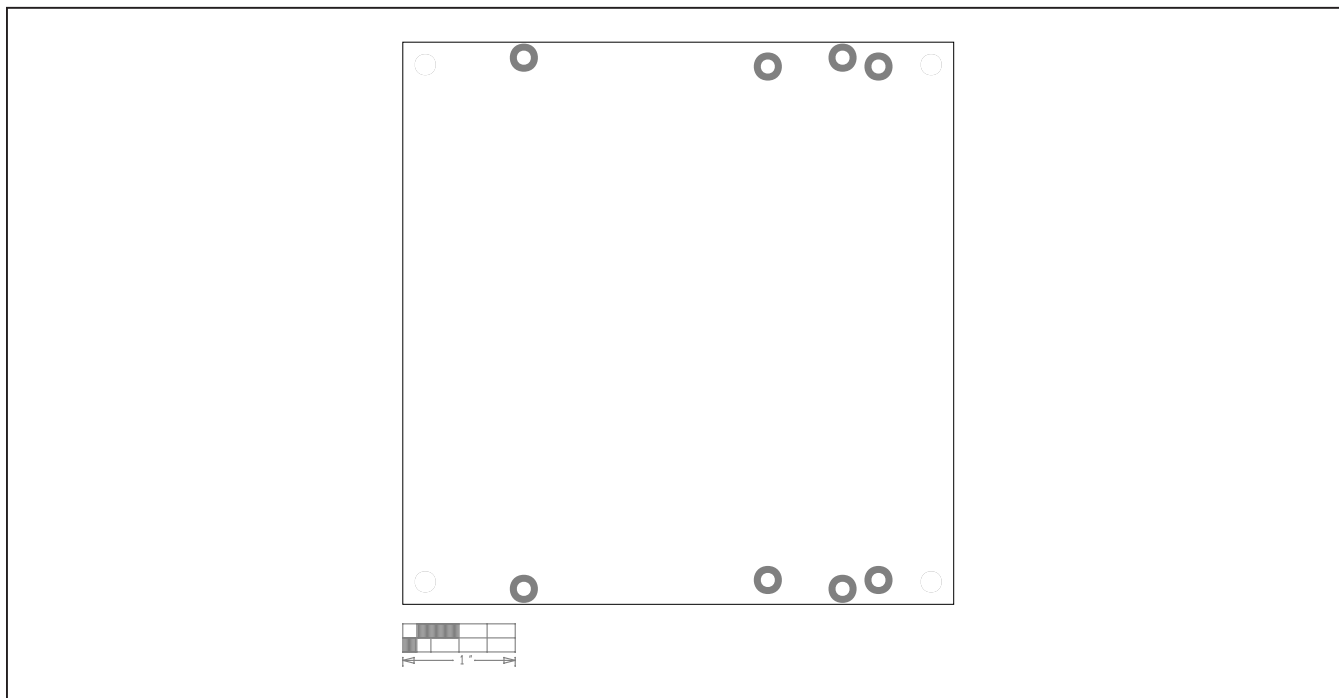

MAX25608 EV Kit Component Placement Guide—Bottom

Revision History

REVISION NUMBER	REVISION DATE	DESCRIPTION	PAGES CHANGED
0	8/21	Initial release	—

For pricing, delivery, and ordering information, please visit Maxim Integrated's online storefront at <https://www.maximintegrated.com/en/storefront/storefront.html>.

Maxim Integrated cannot assume responsibility for use of any circuitry other than circuitry entirely embodied in a Maxim Integrated product. No circuit patent licenses are implied. Maxim Integrated reserves the right to change the circuitry and specifications without notice at any time.