



2SD1857

NPN EPITAXIAL SILICON TRANSISTOR

POWER TRANSISTOR

■ FEATURES

- * High breakdown voltage. ($BV_{CEO}=120V$)
- * Low collector output capacitance. (Typ. 20pF at $V_{CB}=10V$)
- * High transition frequency. ($f_T=80MHz$)

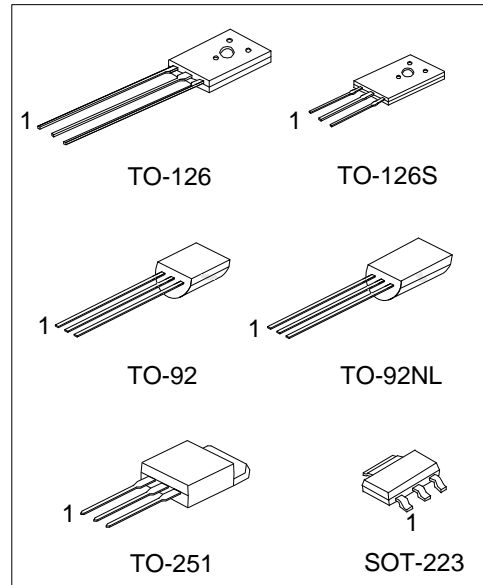

■ ORDERING INFORMATION

Ordering Number		Package	Pin Assignment			Packing
Lead Free	Halogen Free		1	2	3	
2SD1857L-x-AA3-R	2SD1857G-x-AA3-R	SOT-223	B	C	E	Tape Reel
2SD1857L-x-AA3-A-R	2SD1857G-x-AA3-A-R	SOT-223	E	C	B	Tape Reel
2SD1857L-x-T60-K	2SD1857G-x-T60-K	TO-126	E	C	B	Bulk
2SD1857L-x-T6S-K	2SD1857G-x-T6S-K	TO-126S	E	C	B	Bulk
2SD1857L-x-TM3-T	2SD1857G-x-TM3-T	TO-251	E	C	B	Tube
2SD1857L-x-T92-B	2SD1857G-x-T92-B	TO-92	E	C	B	Tape Box
2SD1857L-x-T92-K	2SD1857G-x-T92-K	TO-92	E	C	B	Bulk
2SD1857L-x-T9N-B	2SD1857G-x-T9N-B	TO-92NL	E	C	B	Tape Box
2SD1857L-x-T9N-K	2SD1857G-x-T9N-K	TO-92NL	E	C	B	Bulk

Note: Pin Assignment: E: Emitter C: Collector B: Base

<p>2SD1857G-x-AA3-x-R</p>	<p>(1) Packing Type (2) Pin Assignment (3) Package Type (4) Rank (5) Green Package</p>	<p>(1) R: Tape Reel, B: Tape Box, K: Bulk, T: Tube (2) Refer to Pin Assignment (3) AA3: SOT-223, T60: TO-126, T6S: TO-126S, TM3: TO-251, T92: TO-92, T9N: TO-92NL (4) x: refer to Classification of h_{FE} (5) G: Halogen Free and Lead Free, L: Lead Free</p>
---------------------------	--	---

2SD1857

NPN EPITAXIAL SILICON TRANSISTOR

MARKING

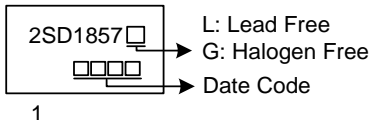
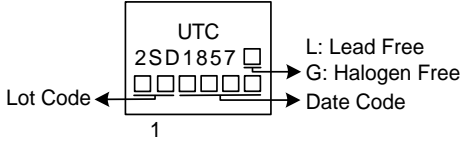
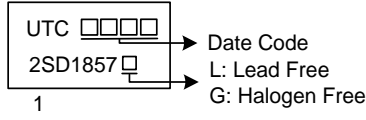
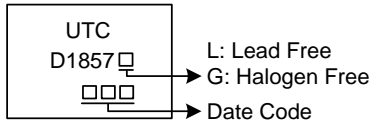
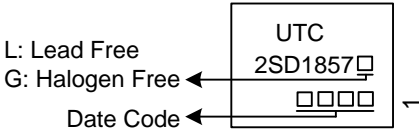
PACKAGE	MARKING
SOT-223	 <p>1</p>
TO-251	 <p>1</p>
TO-126 / TO-126C	 <p>1</p>
TO-92	 <p>1</p>
TO-92NL	

■ ABSOLUTE MAXIMUM RATING (T_A=25°C, unless otherwise specified)

PARAMETER		SYMBOL	RATINGS	UNIT
Collector-Base Voltage		V _{CBO}	120	V
Collector-Emitter Voltage		V _{CEO}	120	V
Emitter-Base Voltage		V _{EBO}	5	V
Collector Power Dissipation	SOT-223	P _C	1 (Note 2)	W
	TO-126/TO-126S		1.4	W
	TO-92		0.625	W
	TO-92 NL		0.9	W
	TO-251		2	W
Collector Current		I _C	2	A
Collector Current		I _{CP}	3	A
Junction Temperature		T _J	+150	°C
Storage Temperature		T _{STG}	-40 ~ +150	°C

Notes: 1. Absolute maximum ratings are those values beyond which the device could be permanently damaged. Absolute maximum ratings are stress ratings only and functional device operation is not implied.
 2. When mounted on a 40×40×0.7mm ceramic board.

■ ELECTRICAL CHARACTERISTICS (T_A=25°C, unless otherwise specified)

PARAMETER	SYMBOL	TEST CONDITIONS	MIN	TYP	MAX	UNIT
Collector-Base Breakdown Voltage	BV _{CBO}	I _C =50μA	120			V
Collector-Emitter Breakdown Voltage	BV _{CEO}	I _C =1mA	120			V
Emitter-Base Breakdown Voltage	BV _{EBO}	I _E =50μA	5			V
Collector Cut-Off Current	I _{CBO}	V _{CB} =100V			1	μA
Emitter Cut-Off Current	I _{EBO}	V _{EB} =4V			1	μA
DC Current Transfer Ratio	h _{FE}	V _{CE} =5V, I _C =0.1A	82		390	
Collector-Emitter Saturation Voltage	V _{CE(SAT)}	I _C =I _B =1A/0.1A (Note)			0.4	V
Transition Frequency	f _T	V _{CE} =5V, I _E =-0.1A, f=30MHz.		80		MHz
Output Capacitance	C _{OB}	V _{CB} =10V, I _E =0A, f=1MHz (Note)		20		pF

Note: Measured using pulse current.

■ CLASSIFICATION OF h_{FE}

RANK	P	Q	R
RANGE	82-180	120-270	180-390

TYPICAL CHARACTERISTICS

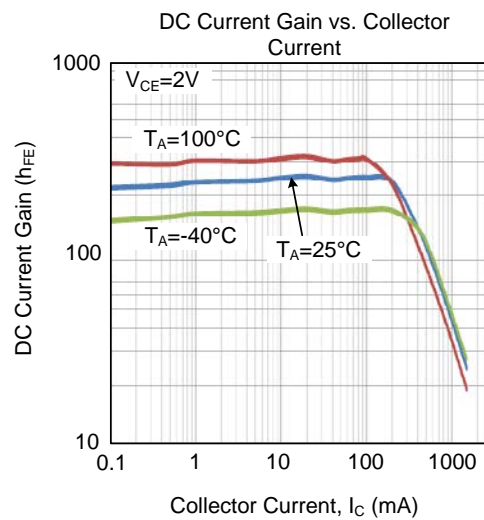
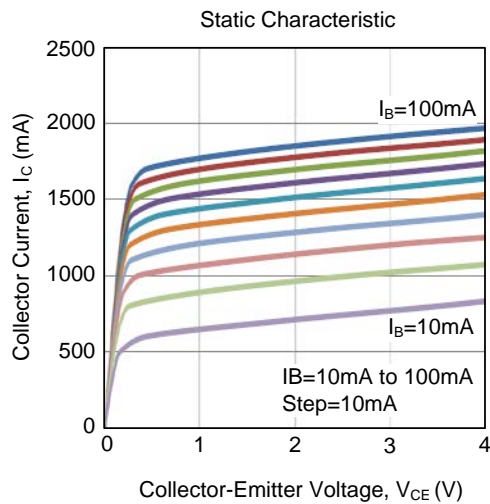
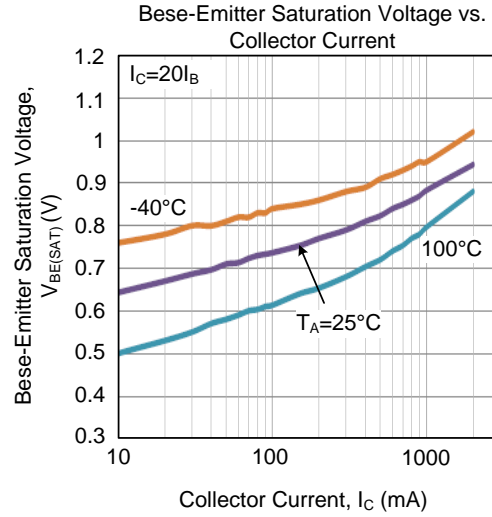
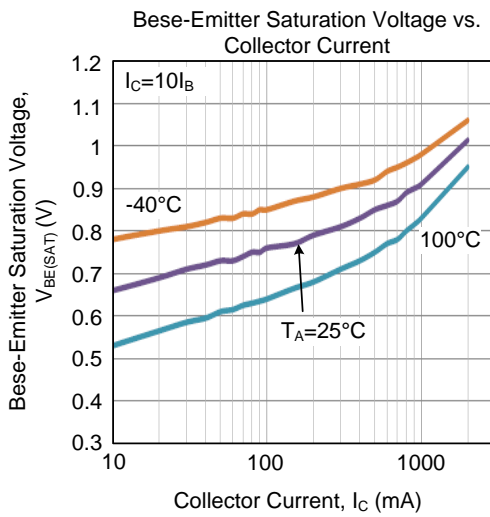
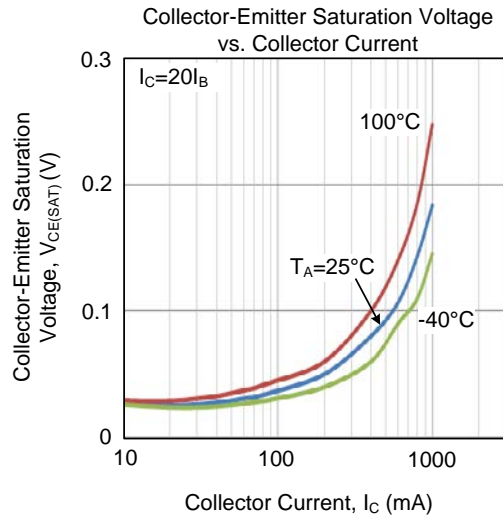
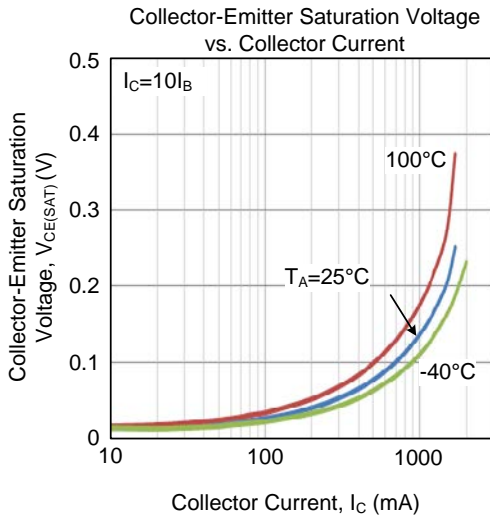

■ TYPICAL CHARACTERISTICS (Cont.)

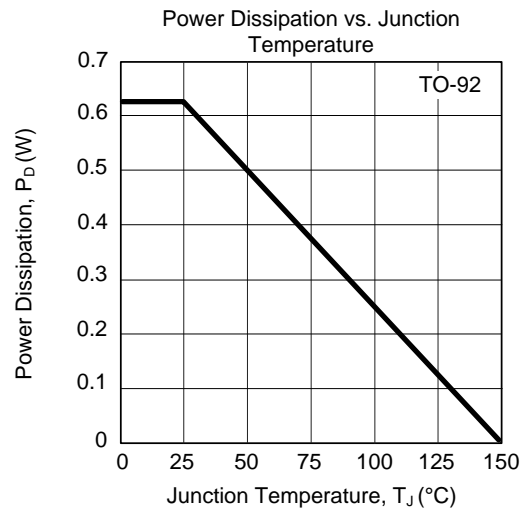
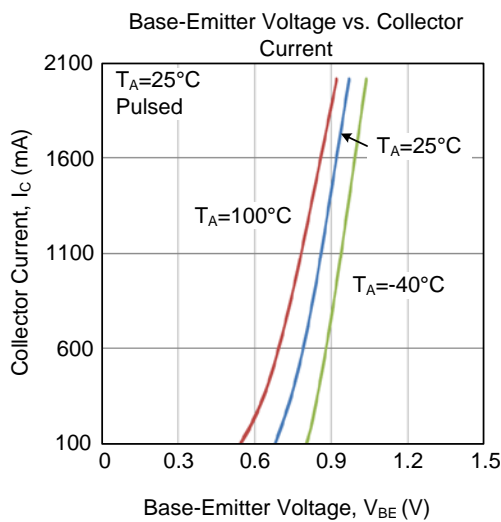
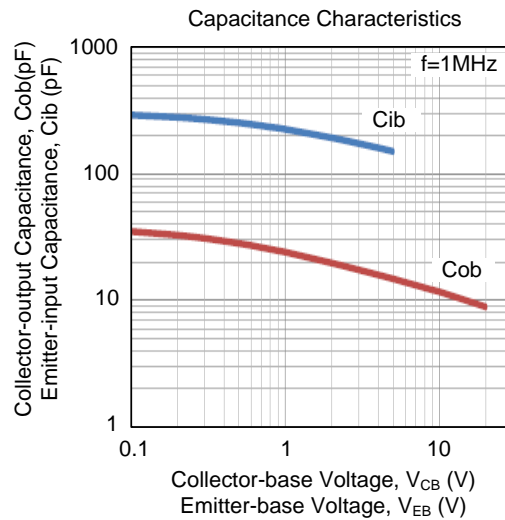
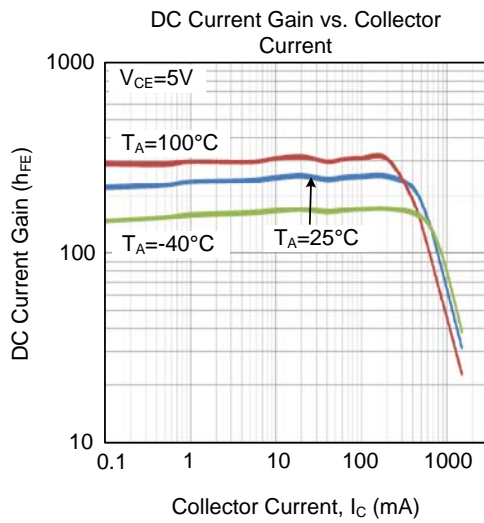

UTC assumes no responsibility for equipment failures that result from using products at values that exceed, even momentarily, rated values (such as maximum ratings, operating condition ranges, or other parameters) listed in products specifications of any and all UTC products described or contained herein. UTC products are not designed for use in life support appliances, devices or systems where malfunction of these products can be reasonably expected to result in personal injury. Reproduction in whole or in part is prohibited without the prior written consent of the copyright owner. UTC reserves the right to make changes to information published in this document, including without limitation specifications and product descriptions, at any time and without notice. This document supersedes and replaces all information supplied prior to the publication hereof.