

REVISIONS

REV.	ECO	DESCRIPTION
B	9758	UPDATED FORMAT

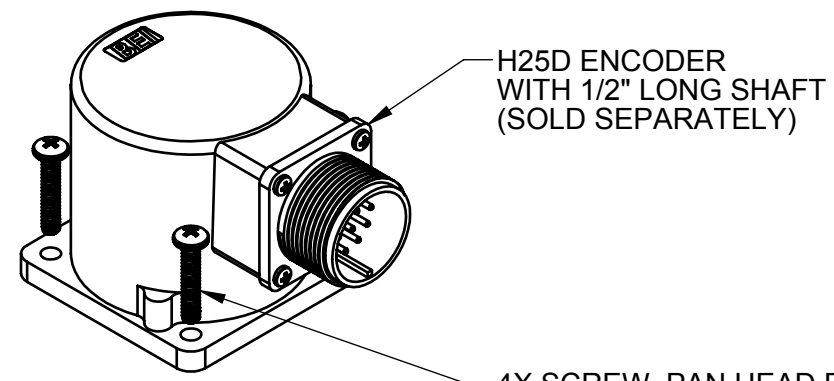

H25D ENCODER WITH 1/2" LONG SHAFT (SOLD SEPARATELY)

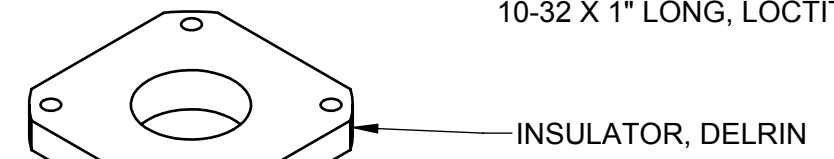

4X SCREW, PAN HEAD PHIL 10-32 X 1" LONG, LOCTITE

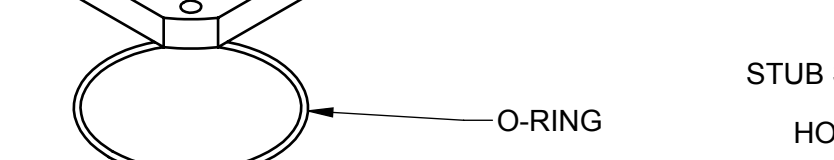

COUPLING, 3/8" X 3/8"

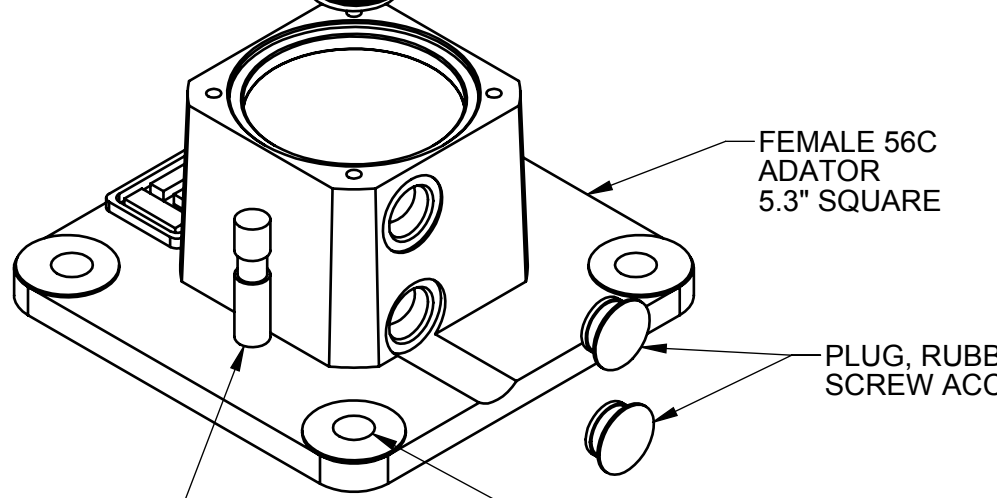

FEMALE 56C ADATOR 5.3" SQUARE

PLUG, RUBBER, COUPLING SCREW ACCESS

STUB SHAFT, TAPE TO ADATOR BODY FOR SHIPMENT (P/N 14186-001)

4X  $\phi$ .437 THRU ON  $\phi$ 5.875 B.C.

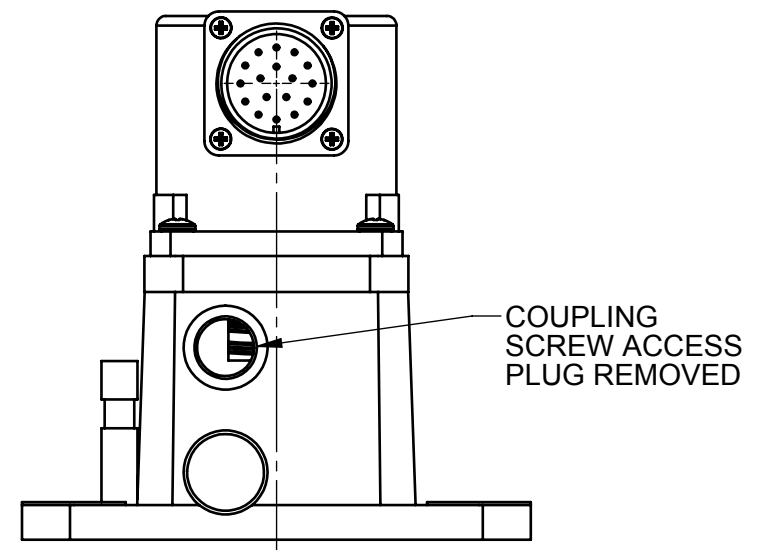
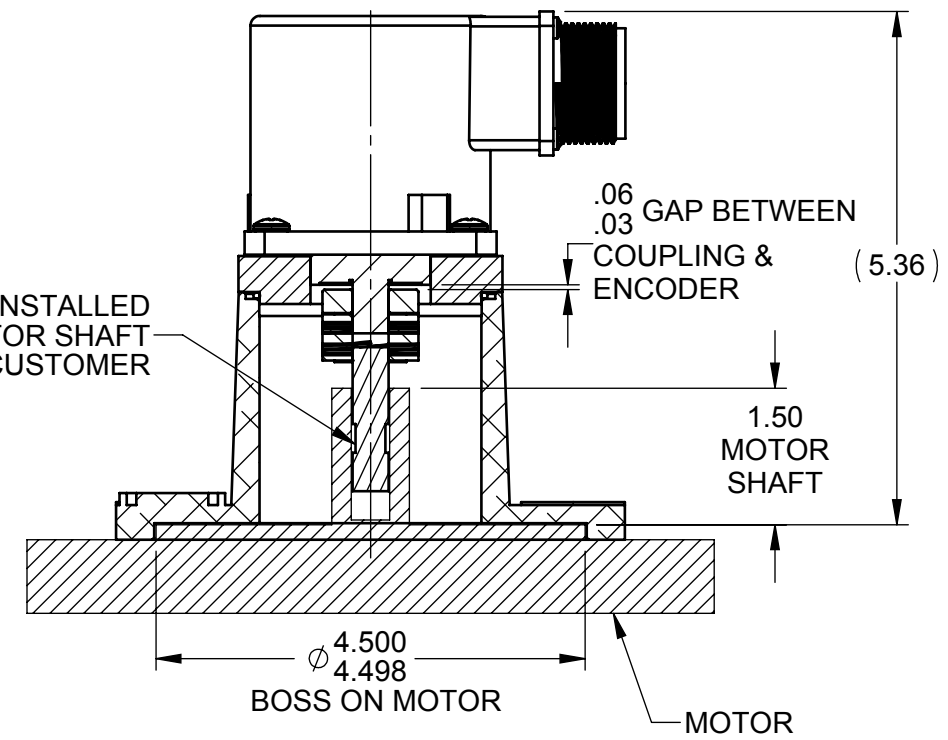

1. PARTS MAY BE INSTALLED BY BEI OR CUSTOMER.

NOTES: UNLESS OTHERWISE SPECIFIED

MATERIAL	FINISH	APPROVALS	DATE
NOTED	NOTED	DRAWN MullerR	5/16/2016
THESE COMMODITIES, TECHNOLOGY OR SOFTWARE IF EXPORTED FROM THE UNITED STATES MUST BE IN ACCORDANCE WITH THE BUREAU OF INDUSTRY, EXPORT ADMINISTRATION REGULATIONS. DIVERSION CONTRARY TO U.S. LAW IS PROHIBITED.		APPROVED	
THIS DOCUMENT CONTAINS PROPRIETARY INFORMATION OF BEI SENSORS. ANY REPRODUCTION, USE OR DISCLOSURE OF THIS DOCUMENT WITHOUT WRITTEN CONSENT OF BEI SENSORS IS EXPRESSLY PROHIBITED.		UNLESS OTHERWISE SPECIFIED, DIMENSIONS ARE IN INCHES AND APPLY AFTER FINISH .XX $\pm$ .01 .XXX $\pm$ .005 ANGLES $\pm$ 0' 30' ALL DIA. TO BE $\odot$ WITHIN .010	

**BEI SENSORS** 1461 Lawrence Dr.  
Thousand Oaks, Ca. 91320  
Tel: (805) 716-0322  
Fax: (805) 968-3154

TITLE: NEMA 56C TOPHAT ASSEMBLY  
H25 FEMALE WITH STUB SHAFT

SIZE	CAGE CODE	DWG. NO.	REV.
B	1RB90	11012-004	B

SCALE: 1:2 FILE: SHEET 1 OF 1

# Mouser Electronics

Authorized Distributor

Click to View Pricing, Inventory, Delivery & Lifecycle Information:

[Sensata:](#)

[11012-004](#)